

# SANDEL<sup>®</sup>

## ST3400

### TAWS/RMI

*With Traffic Capability*

# Installation Manual

Document No. 82002-IM

Revision J1

09/01/04

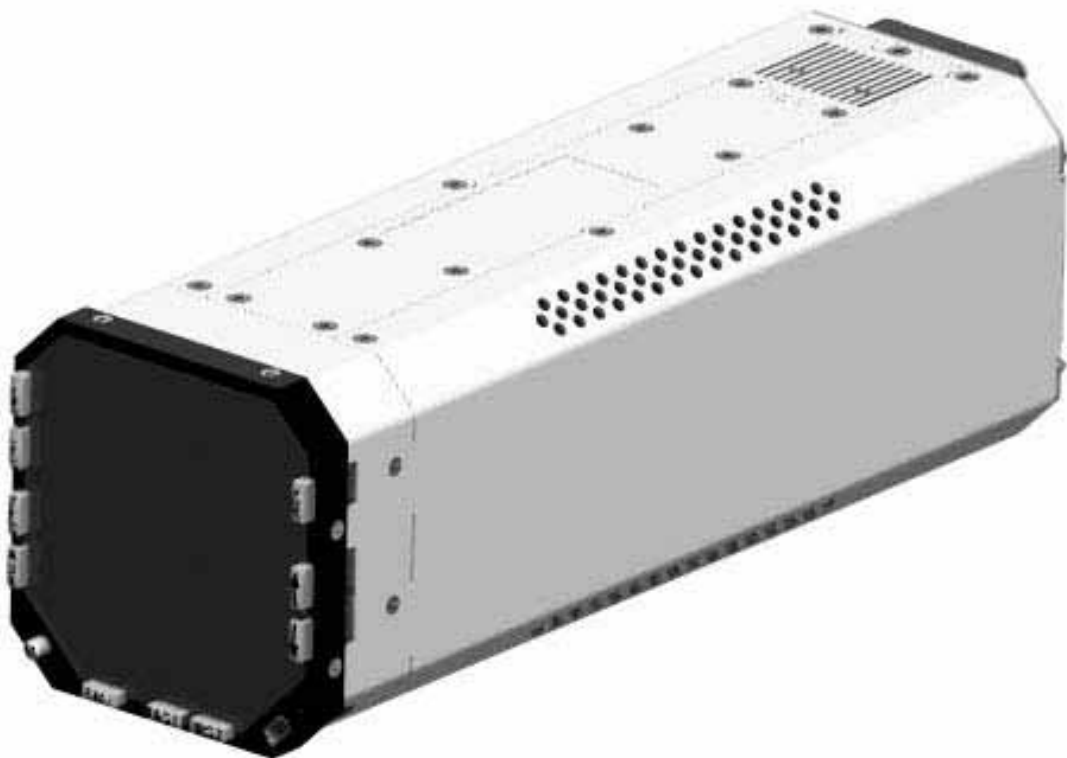

**SANDEL AVIONICS**  
2401 DOGWOOD WAY  
VISTA, CA 92081  
PHONE (760) 727-4900  
FAX (760) 727-4899  
WEBSITE [WWW.SANDEL.COM](http://WWW.SANDEL.COM)  
EMAIL [SUPPORT@SANDEL.COM](mailto:SUPPORT@SANDEL.COM)

## Revision History

<b>Rev</b>	<b>Date</b>	<b>Comments</b>
J1	09/01/04	Incorporated A/R 740 Added error message list.
J	08/05/04	Incorporated A/R 717 Added information about Mod-A; Speaker Audio Added Airdata AZ-648 Interface
H2	04/15/04	Incorporated A/R 697 Changed installation drawings list of effective pages for audio enable relay
H1	03/17/04	Incorporated A/R 690 Added Airdata AZ-600 Interface
H	02/18/04	Incorporated A/R 675 Removed #2 Radar Altimeter input Removed #2 Analog Airdata input Added FreeFlight 1201 WAAS GPS Added Decision Height Input for Radar Altimeter Added Altitude Callouts from radar altimeter Added Back Course Input from HSI Added CIC8800M & Penny & Giles D60286 Updated pin info on P3-8 selectable discrete out Updated P1, P2, & P3 Pinouts Updated Flap XYZ Input on Dwg 19 Added Flap, Glideslope Annunciators and Override Input Added Traffic Interface Updated King Air STC
G1	10/17/03	Incorporated A/R 661 Added GPS interface King KLN900. Trimble 2000/3000/2101 and UPS GX Series Added Airdata Collins ADC 80 Manchester Buss Interface, Added Airdata Collins ADC85 Added Windshield Wiper Discrete Input
G	8/04/03	Incorporated A/R 638 Corrected Part Number of ST3400 Class B Gray Added GPS interface Trimble 2101 I/O. Added Airdata IS&S ADDU Added separate TCAS Inhibit Output Added Configuration Module Description

F	4/15/03	<p>Incorporated A/R 626  Note about C92 GPWS systems  HDG added to Req'd equip list.  Note added in GEAR section about fixed-gear aircraft  Note on flaps in 'takeoff' configuration  Added GPS interface King KLN94  Added Airdata Collins ADC82 (), Honeywell AM-250 &amp; AZ-810  Added OAT RS232 Interface  Added Flap XYZ Interface  Corrected missing 'x' in class-A configuration chart  Note about discrete inputs in signal characteristics table  Corrected various typographical errors</p>
---	---------	--

E	02/21/03	<p>Incorporated A/R-610 – Software version 2.00</p> <p>Added sensor configuration charts and Airdata chart</p> <p>Added reference to ST3400 Component Maintenance Manual</p> <p>Added GPS interface II Morrow 2001, 2101 and Universal UNS-1X</p> <p>Added Garmin 4XX &amp; 5XX RS232 interface.</p> <p>Added Bendix/King KRA405 &amp; KRA405B, and Sperry RT220 &amp; RT300.</p> <p>Added Collins ADF-462 &amp; ADF60A/B and Bendix/King KR-87.</p> <p>Added Nav Rx's Bendix/King KX155/165, Collins VIR30/31, VIR432 and Garmin 430/530.</p> <p>Added Airdata Honeywell AZ-252.</p> <p>Removed references to negative climb rate after takeoff.</p> <p>Revised notes on 1.05 actually apply to 2.00</p>
D(2)	10/24/02	<p>Incorporated A/R-578</p> <p>Added ADC-80 Interface Removed incorrect callouts on P2</p>
D(1)	10/02/02	<p>Incorporated A/R-572</p> <p>4.9 Added Signal Characteristics Table</p> <p>4.5 – 4.7 Reformatted pin tables</p> <p>Added signal characteristics to pin tables</p>
D	09/25/02	<p>Incorporated A/R 564</p> <p>Flaps changed to required input.</p> <p>RA1 FAIL and RA2 FAIL added</p> <p>Windshield Wiper shared with RA2 FAIL</p> <p>Note on configuration module</p> <p>Added Gamin 165 GPS Interface</p> <p>Added Penny &amp; Giles Airdata</p>
C	06/18/02	<p>A/R 547:</p> <p>Software 1.04/1.05 Notes; OAT; GPS Altitude</p>
B1	05/29/02	<p>Incorporated A/R 525</p> <p>TOC: Corrected Radar Altimeter Error</p> <p>1.2.6 Removed GPS Altitude</p>
B	05/21/02	<p>Incorporated A/R 525</p> <p>Added reference to Patents</p> <p>1.2.2 Updated Class B Air Data Requirements</p> <p>3.4 Removed Alert Test</p> <p>3.13 Removed reference to GPS Altitude</p> <p>6.3.8 Removed reference to software 1.10</p> <p>Dwg Page 1, Updated Block Diagram</p> <p>Dwg Page 2, Updated Block Diagram</p> <p>Dwg Page 10, Updated Air Data</p>
A	04/12/02	Initial Release

## Approvals

Prepared By: Art L. Rosa Date 9-01-04

Art Rosa, Tech Support

Reviewed By: Murray Kerslake Date 9-1-04

Murray Kerslake, QA

Approved By: G. Block Date 9-01-04

Gerald J. Block, Director of Engineering

# TABLE OF CONTENTS

<b>1</b>	<b>GENERAL INFORMATION .....</b>	<b>1-11</b>
<b>1.1</b>	<b>Introduction.....</b>	<b>1-11</b>
1.1.1	MOD-A Status .....	1-11
<b>1.2</b>	<b>Descriptions .....</b>	<b>1-11</b>
1.2.1	ST3400 TAWS/RMI Description .....	1-11
1.2.2	TAWS Description.....	1-12
1.2.3	TAWS Class A/Class B Required Equipment .....	1-13
1.2.4	FAA TAWS Requirement by Type of Operation .....	1-14
1.2.5	RMI Description .....	1-14
1.2.6	Terrain Database .....	1-14
1.2.7	Coverage area of the databases .....	1-14
1.2.8	Keeping the databases current .....	1-15
<b>1.3</b>	<b>Technical Specifications .....</b>	<b>1-15</b>
1.3.1	Approval Data.....	1-15
1.3.2	Physical Dimensions.....	1-15
1.3.3	Operational Characteristics .....	1-16
<b>1.4</b>	<b>Interface Characteristics .....</b>	<b>1-17</b>
<b>1.5</b>	<b>Part Numbers .....</b>	<b>1-18</b>
1.5.1	ST3400 Part Number .....	1-18
1.5.2	Installation Kit Part Number .....	1-18
<b>1.6</b>	<b>License Requirements.....</b>	<b>1-18</b>
<b>1.7</b>	<b>Technical Standard Order Stipulation .....</b>	<b>1-19</b>
<b>1.8</b>	<b>Installation and Operational Approval Procedures .....</b>	<b>1-19</b>
<b>2</b>	<b>INSTALLATION PLANNING .....</b>	<b>2-1</b>
<b>2.1</b>	<b>General Information.....</b>	<b>2-1</b>
<b>2.2</b>	<b>Allowed Sensor Configuration Matrix – Class A.....</b>	<b>2-1</b>
2.2.1	Required Sensors (Class-A).....	2-1
2.2.2	Additional Required Sensors, allowed configurations (Class-A).....	2-1
<b>2.3</b>	<b>Allowed Sensor Configuration Matrix – Class B.....</b>	<b>2-1</b>
2.3.1	Required Sensors (Class-B) .....	2-1
2.3.2	Additional Required Sensors, allowed configurations (Class-B) .....	2-2
2.3.3	Optional Capabilities for Class-B, needed Sensors .....	2-2
<b>2.4</b>	<b>Altitude Sources and Airdata .....</b>	<b>2-2</b>
2.4.1	Airdata System Block Diagram .....	2-3

2.4.2	OAT Requirements .....	2-4
<b>2.5</b>	<b>Pre-installation Planning.....</b>	<b>2-4</b>
<b>2.6</b>	<b>Post Installation Procedures .....</b>	<b>2-5</b>
<b>3</b>	<b>INTERFACE FUNCTIONS.....</b>	<b>3-1</b>
<b>3.1</b>	<b>Dual Inputs .....</b>	<b>3-1</b>
<b>3.2</b>	<b>Power.....</b>	<b>3-1</b>
<b>3.3</b>	<b>External Annunciators .....</b>	<b>3-1</b>
<b>3.4</b>	<b>Flaps .....</b>	<b>3-2</b>
<b>3.5</b>	<b>Landing Gear .....</b>	<b>3-2</b>
<b>3.6</b>	<b>Autopilot .....</b>	<b>3-2</b>
<b>3.7</b>	<b>Audio Panel .....</b>	<b>3-3</b>
<b>3.8</b>	<b>GPS/FMS .....</b>	<b>3-3</b>
<b>3.9</b>	<b>Radar Altimeter .....</b>	<b>3-3</b>
<b>3.10</b>	<b>Heading System.....</b>	<b>3-4</b>
<b>3.11</b>	<b>ADF Receiver .....</b>	<b>3-4</b>
<b>3.12</b>	<b>NAV Receiver and Glideslope.....</b>	<b>3-5</b>
<b>3.13</b>	<b>Air Data Computer .....</b>	<b>3-5</b>
<b>3.14</b>	<b>OAT Probe.....</b>	<b>3-5</b>
<b>3.15</b>	<b>Traffic.....</b>	<b>3-6</b>
<b>3.16</b>	<b>ST3400 Interlink .....</b>	<b>3-6</b>
<b>3.17</b>	<b>Uploading Equipment.....</b>	<b>3-6</b>
<b>3.18</b>	<b>Display Dimming.....</b>	<b>3-6</b>
<b>3.19</b>	<b>Windshield Wipers.....</b>	<b>3-6</b>
<b>4</b>	<b>INSTALLATION.....</b>	<b>4-1</b>
<b>4.1</b>	<b>Unpacking and Inspecting Equipment .....</b>	<b>4-1</b>
<b>4.2</b>	<b>Cooling Considerations .....</b>	<b>4-1</b>

<b>4.3</b>	<b>Mechanical Installation Considerations .....</b>	<b>4-1</b>
4.3.1	Instrument Location in the Cockpit .....	4-1
4.3.2	Assembly and Mounting Instructions .....	4-1
<b>4.4</b>	<b>Electrical Installation Considerations.....</b>	<b>4-2</b>
<b>4.5</b>	<b>Connector P1 .....</b>	<b>4-3</b>
4.5.1	View of Mating Connector to P1 .....	4-5
<b>4.6</b>	<b>Connector P2 .....</b>	<b>4-6</b>
4.6.1	View of Mating Connector to P2 .....	4-8
<b>4.7</b>	<b>P3 Connector .....</b>	<b>4-9</b>
4.7.1	View of Mating Connector to P3 .....	4-9
<b>4.8</b>	<b>P4 Connector .....</b>	<b>4-10</b>
<b>4.9</b>	<b>Signal Type Electrical Characteristics.....</b>	<b>4-11</b>
<b>5</b>	<b>MAINTENANCE MODE .....</b>	<b>5-1</b>
<b>5.1</b>	<b>Normal Mode Operation .....</b>	<b>5-1</b>
<b>5.2</b>	<b>Maintenance Mode.....</b>	<b>5-1</b>
<b>6</b>	<b>SETUP PROCEDURES .....</b>	<b>6-1</b>
<b>6.1</b>	<b>General.....</b>	<b>6-1</b>
6.1.1	Accessing Maintenance Pages .....	6-1
6.1.2	Uploading Data or System Software.....	6-1
6.1.3	Configuration Module.....	6-1
6.1.4	Configuration Module Status Page .....	6-2
6.1.5	Tail Number .....	6-2
<b>6.2</b>	<b>Maintenance Index Page .....</b>	<b>6-3</b>
6.2.1	Maintenance Page Number/Title .....	6-3
6.2.2	Cursor.....	6-3
6.2.3	Soft Keys.....	6-4
6.2.4	Edit/Read Mode Indicator.....	6-5
6.2.5	How to Access Maintenance Pages .....	6-5
<b>6.3</b>	<b>Maintenance Pages.....</b>	<b>6-6</b>
6.3.1	System Maintenance Page .....	6-6
6.3.2	Air Data Page.....	6-7
6.3.3	ADF & HDG Page .....	6-8
6.3.4	Discretes Maintenance Page .....	6-9
6.3.5	NAV and ILS Page .....	6-10
6.3.6	RADALT Maintenance Page.....	6-11
6.3.7	GPS/FMS .....	6-12

6.3.8	TCAS .....	6-13
6.3.9	Status Page .....	6-14
6.3.10	Callouts .....	6-15
<b>7</b>	<b>POST INSTALLATION .....</b>	<b>7-1</b>
<b>7.1</b>	<b>General.....</b>	<b>7-1</b>
7.1.1	Accessing Maintenance Pages .....	7-1
<b>7.2</b>	<b>Post Installation Testing.....</b>	<b>7-2</b>
7.2.1	Power-On Self-Test .....	7-2
7.2.2	ST3400 TAWS/RMI.....	7-2
7.2.3	Install Sandel ST3400 TAWS/RMI into aircraft .....	7-2
7.2.4	Record the following Aircraft Configuration .....	7-2
7.2.5	Record the following system information: .....	7-2
7.2.6	Required Test Equipment: .....	7-2
7.2.7	Brightness/Audio Page.....	7-3
7.2.8	Alerts Test.....	7-3
7.2.9	Power Maintenance Page .....	7-4
7.2.10	Software CRC Page .....	7-5
7.2.11	ST3400 CONFIGURATION .....	7-5
7.2.12	AIR DATA INPUT TESTS .....	7-8
7.2.13	ADF INPUT TESTS .....	7-9
7.2.14	HEADING INPUT TESTS.....	7-9
7.2.15	DISCRETE INPUTS TESTS.....	7-10
7.2.16	NAV& ILS INPUT TESTS .....	7-10
7.2.17	RADAR ALTIMETER.....	7-11
7.2.18	GPS/FMS 1 .....	7-12
7.2.19	GPS/FMS 2 .....	7-13
7.2.20	TRAFFIC .....	7-13
7.2.21	Activate the TAWS Inhibit.....	7-13
7.2.22	Power up the GPS/FMS.....	7-13
7.2.23	Initialize GPS/FMS.....	7-14
7.2.24	Fail the GPS/FMS.....	7-14
7.2.25	Run TAWS self-test.....	7-14
7.2.26	Verify the ST3400 display .....	7-14
7.2.27	Verify the ST3400 manual display .....	7-14
7.2.28	Verify the ST3400 visibility and accessibility.....	7-15
<b>8</b>	<b>INSTRUCTIONS FOR CONTINUED AIRWORTHINESS .....</b>	<b>8-1</b>
<b>8.1</b>	<b>General.....</b>	<b>8-1</b>
<b>8.2</b>	<b>Databases .....</b>	<b>8-1</b>
<b>8.3</b>	<b>Lamp Replacement.....</b>	<b>8-1</b>
<b>8.4</b>	<b>Software Updates .....</b>	<b>8-1</b>

<b>9</b>	<b>INSTALLATION DRAWINGS</b> .....	<b>9-1</b>
<b>10</b>	<b>APPENDIX A: EQUIPMENT AND INTERFACES</b> .....	<b>10-1</b>
<b>10.1</b>	<b>GPS/FMS</b> .....	<b>10-1</b>
10.1.1	ARINC 429 LABELS for GPS/FMS .....	10-2
<b>10.2</b>	<b>RADAR ALTIMETER</b> .....	<b>10-2</b>
10.2.1	ARINC 429 LABELS for Radar Altimeter .....	10-3
<b>10.3</b>	<b>HEADING</b> .....	<b>10-3</b>
10.3.1	ARINC 429 LABELS for Heading.....	10-3
<b>10.4</b>	<b>ADF</b> .....	<b>10-3</b>
10.4.1	ARINC 429 LABELS for ADF .....	10-3
<b>10.5</b>	<b>NAV</b> .....	<b>10-3</b>
10.5.1	ARINC 429 LABELS for NAV .....	10-3
<b>10.6</b>	<b>AIRDATA</b> .....	<b>10-4</b>
10.6.1	ARINC 429 LABELS for Airdata .....	10-4
<b>10.7</b>	<b>TRAFFIC</b> .....	<b>10-4</b>
<b>11</b>	<b>APPENDIX B: ENVIRONMENTAL QUALIFICATION FORM</b> .....	<b>11-1</b>
<b>12</b>	<b>APPENDIX C: STC</b> .....	<b>12-1</b>
<b>12.1</b>	<b>STC Permission</b> .....	<b>12-1</b>
<b>12.2</b>	<b>STC: Cessna 421C Series</b> .....	<b>12-2</b>
<b>12.3</b>	<b>STC: King Air C90, 200, 300 and B300 Series</b> .....	<b>12-3</b>

# 1 GENERAL INFORMATION

## 1.1 Introduction

The information contained within this Installation Manual describes the features, functions, technical characteristics, components, approval procedures, installation considerations, setup procedures, checkout procedures and instructions for continued airworthiness for the Sandel Avionics ST3400 TAWS/RMI.

Sandel Avionics ST3400 TAWS/RMI may be covered by one or more U.S. and foreign patents and pending patent applications, including U.S. Patent Nos. 6,507,288, 6,489,916, and 6,259,378.

### 1.1.1 MOD-A Status

Certain enhancements exist on units marked as “MOD-A” on the dataplate. These enhancements cannot be retrofitted to non MOD-A units.

1. The display has higher resolution
2. 2<sup>nd</sup> audio output available which can drive 8 ohm speaker directly
3. Availability of auto dimming of the display from the Pilot’s Menu.
4. Cooling Fan will cycle off below approximately 0° C
5. Self-test will operate all annunciator outputs.
6. Capability of interfacing to CIC brand analog airdata Computers

Mod-A status can be determined from the data plate, or from the Pilot’s Menu where the Mod-A status is shown in the upper right of the screen.

NOTE: See section on software loading for other information about MOD-A.

## 1.2 Descriptions

### 1.2.1 ST3400 TAWS/RMI Description

The Sandel ST3400 is a self-contained TAWS (Terrain Awareness Warning System) solution that includes a TAWS computer and an integrated full-color screen, built within a standard 3-inch instrument chassis.

It can be used as a direct replacement for a currently installed RMI (Radio Magnetic Indicator).

The ST3400 uses Sandel’s patented rear-projection display technology. The projector uses a miniature active-matrix LCD display that produces a high-resolution image that is rear-projected directly to the face of the instrument. This technology allows the displayed image to extend to the edges of the instrument’s bezel. The advantage of this edge-to-edge technology is that it eliminates the unusable area surrounding conventional LCD and CRT displays. Even though the Sandel display is in a 3-inch form factor, its image is near the size of a 4” primary display, and it remains directly in the pilot’s field-of-view.

The ST3400 includes built-in warning and caution annunciation. The unit also supports optional external warning or caution annunciation.

The ST3400 may be installed in a pilot-only or dual pilot/copilot configuration.

The ST3400 has an internal recorder that automatically records ten hours of flight data. This data can be reviewed for content in the event of a system malfunction.

### 1.2.2 TAWS Description

TAWS is the enhanced terrain warning technology that replaces the older GPWS (Ground Proximity Warning System) technology. It is also known as EGPWS (Enhanced GPWS).

TAWS adds two new and critical capabilities, FLTA (Forward Looking Terrain Avoidance) and PDA (Premature Decent Alert) to the standard GPWS functions.

The six standard GPWS functional modes are:

- ERD (excessive rate of descent)
- ECRT (excessive closure rate to terrain)
- ALAT (altitude loss after takeoff)
- FITNL (flight into terrain when not in landing configuration)
- EDGSD (excessive downward glide slope deviation).
- 500' Voice Callout

The ST3400 can be configured either as a Class A TAWS compliant system or as a Class B TAWS compliant system depending on the availability of radar altimeter and airdata.

When configured as a Class B TAWS system, the ST3400 exceeds Class B TAWS requirements. Even in Class B mode without radar altimeter, the ST3400 has additional Class A features such as a display and an excessive glide slope deviation alert. See the POH for additional information

CLASS A TAWS FUNCTIONAL REQUIREMENTS	
Mode	Function
FLTA	Forward Looking Terrain Alert
PDA	Premature Descent Alert
GPWS Mode 1	Excessive Rate of Descent
GPWS Mode 2	Excessive Closure Rate to Terrain
GPWS Mode 3	Altitude Loss After Takeoff
GPWS Mode 4	Flight Into Terrain Not in Landing Configuration
GPWS Mode 5	Excessive Downward Deviation from Glideslope
GPWS Mode 6	Voice callout "Five Hundred" when the aircraft descends through 500 feet Radar Altitude

Class A TAWS requires a display, which shows the aircraft in relation to the terrain. Satisfied by the ST3400 dedicated display.

Class A TAWS requires a radar altimeter (for GPWS functions).

<b>CLASS B TAWS FUNCTIONAL REQUIREMENTS</b>	
<b>Mode</b>	<b>Function</b>
FLTA	Forward Looking Terrain Alert
PDA	Premature Descent Alert
GPWS Mode 1	Excessive Rate of Descent
GPWS Mode 3	Altitude Loss After Takeoff
GPWS Mode 6	Voice callout “Five Hundred” when the aircraft descends to 500 feet above the nearest runway elevation

When configured as a Class B TAWS system, the ST3400 exceeds the FAA Class B TAWS requirements. Even in Class B mode without radar altimeter, the ST3400 includes Class A features such as a terrain display and an excessive glide slope deviation alert, when so configured.

### 1.2.3 TAWS Class A/Class B Required Equipment

The ST3400 uses the following equipment to meet Class A or Class B requirements.

<b>ST3400 CLASS A TAWS EQUIPMENT REQUIREMENTS</b>		
<b>Equipment</b>	<b>Class A</b>	<b>Class B</b>
Terrain Display	Integrated	Integrated
Radar Altimeter	Required	Optional
GPS or FMS System	Required	Required
Heading System	Required	Required
Audio Panel	Required	Required
Air Data Computer	Required	Dependent on GPS
Remote Switch/Annunciators	Optional in single pilot aircraft; required in two-crew aircraft	Optional
Flap Position	Required	Recommended
Gear Position	Required if retract gear	Recommended
ILS Receiver	Required	Recommended
NAV	Optional (for RMI)	Optional (for RMI)
ADF	Optional (for RMI)	Optional (for RMI)
OAT Probe	Required for Corrected Baro Alt	Required for Corrected Baro Alt

### 1.2.4 FAA TAWS Requirement by Type of Operation

The FAA has mandated that all U.S.-registered turbine powered aircraft that have six or more passenger seats be equipped with a TAWS no later than March 5, 2005.

Depending on the number of seats and the type of operation, the TAWS requirement will be for a Class A system or a Class B system.

FAA TAWS REQUIREMENT BY TYPE OF OPERATION		
Class	Type of Operation	Number of Passenger Seats
Class A	FAR Part-121	ALL
Class A	FAR Part-135	10 or more
Class B	FAR Part-135	6-9
Class B	FAR Part-91	6 or more

### 1.2.5 RMI Description

The ST3400 RMI function is provided to allow the ST3400 to replace an existing installed electromechanical RMI. The Sandel RMI displays aircraft heading information on a calibrated compass card read against a fixed lubber line.

Bearing is provided to both a primary pointer and a secondary pointer, each of which is read against the compass card.

Each pointer may be switched independently to any installed navigation source, which may be a VOR, ADF, or the GPS/FMS waypoint. The ability to assign the GPS/FMS to a bearing pointer is unique to the ST3400 RMI.

If the navigation source has an invalid state available, the associated bearing pointer will be removed completely from the display instead of being parked at 90° as is common in mechanical RMI's. Each pointer may be independently turned on or off and independently selected to the aircraft navigation sources.

### 1.2.6 Terrain Database

The ST3400 provides predictive "look ahead" warnings by comparing it's internal terrain database to positioning information provided by the GPS, INS, or FMS system. The terrain database includes obstacles. For a Class A installation, additional information is received from a radar altimeter. Altitude information is received from GPS or airdata computer.

### 1.2.7 Coverage area of the databases

The internal databases of the ST3400 contain terrain including charted man-made obstacles, and airports with runways greater than 2500 feet in length or as indicated in the airport database notes. Obstacles are not shown discretely, but are included in the terrain cells. This means, for instance, that flat terrain with a

charted broadcast antenna may show the terrain cell containing the antenna as Yellow when all the surrounding terrain shows as Green.

The Terrain and Airport databases are provided by geographical area. The coverage area of the database installed in the ST3400 is shown as part of the sign-on screen after a power cycle.

Obstacle data from North America and Europe is currently incorporated in the respective terrain databases. Additional obstacle data will be included as more obstacles become charted and information becomes available.

Remember, there is no guarantee that every obstacle is charted or that every charted obstacle is in the terrain data.

### **1.2.8 Keeping the databases current**

Updates to the coverage area databases can be obtained on CD ROM from Sandel or downloaded from the Sandel web site into a Windows loader program on a laptop computer. The terrain data and/or airport data is then downloaded from the PC into the ST3400 through a high-speed USB port located on the front right corner. Loading instructions are supplied along with the applicable database.

The databases can be updated during normal maintenance to the aircraft.

Note: since USB is not supported in Windows-95, only Windows-98 (and later) Microsoft operating systems are supported.

## **1.3 Technical Specifications**

The following section describes the technical characteristics, which include the appliance approval basis, physical and electrical properties, electrical connector pin allocation which details function and gradient or equipment protocol, and ARINC label support. Also included is the description of the ST3400 installation components, other equipment and installation requirements. A review of the installation approval procedures is provided for filing with authorities.

### **1.3.1 Approval Data**

Technical Standard Order: TSO-151b (Class A/Class B) \*

TSO-C113

Software Certification: DO-178B

Environmental: DO-160D

Databases: DO-200A

\*Note: C151b is inclusive of TSO C92 and the ST3400 may be used to replace/upgrade C92 Ground Proximity Warning Systems

### **1.3.2 Physical Dimensions**

The ST3400 is enclosed in an ARINC 408, 3ATI form factor enclosure and is mounted to an instrument panel.

Form Factor: 3ATI (ARINC 408)

Width: 3.175 inches  
Height: 3.175 inches  
Length: 9.5 inches  
Weight: 3.2 pounds with connectors and configuration module.  
(Cable weight not included)  
Mounting: Clamp  
Display: 1 mega-pixel, 256 color (144,000 color triad)

### **1.3.3 Operational Characteristics**

Temperature/Altitude: -20° C to +70° C / up to 55,000 F  
Power Input: 28VDC nominal, 40 watt maximum. Operating range  
22VDC – 33VDC  
Cooling Requirements: Internal fan. Requires ambient air at fan input along  
the four corners of the 3ATI case.

## 1.4 Interface Characteristics

Sandel pioneered smart interface technology makes the ST3400 compatible with all vintages of digital and analog aircraft systems.

The ST3400 is software configurable and configuration data is stored internally and in an optional airframe-resident configuration module (active in software 2.10 and later). No hard-wired jumpers are used.

Configuration Module	Rear mounted configuration module inside 9-pin 'D' connector shell (optional)
Data Loading	12Mbs USB Port using Microsoft Windows compatible computer. Windows 98 and later required.
GPS/FMS	ARINC 429 or RS232
Air Data	ARINC 429 or Analog
Heading	ARINC 429 or XYZ (ARINC 407)
Gear	ARINC 429 Label 270 or Discrete active high or low. Active State = Gear Down
Flap	ARINC 429 Label 270 or Discrete active high or low. Active State = Flaps in Landing Configuration
Autopilot Engage	ARINC 429 or Discrete active high or low. Active State = Autopilot Engaged
RMI	ADF: ARINC 429 or DC Sin/Cos or Arinc 407 XYZ VOR: ARINC 429 or Composite Video
Glideslope	ARINC 429 or low-level deviation and flag
Localizer	ARINC 429 or Composite Analog ILS (ARINC 710)
NAV	ARINC 429 or Composite Analog VOR (ARINC 711)
Alert Audio (LL)	600 ohm unbalanced + 14 dbm maximum
Alert Audio (Spkr)	8 ohm, 4 watt max
External Annun	Lamps Ground = Active, 250ma maximum (optional)
Radar Altimeter	ARINC 429 or 0-2000 ft or 0 – 2,500 ft in ARINC 565, Alt-50, Alt-55 analog format, Sperry RT220/300 analog format, 0-2500 ft at –4mV per Ft.
TRAFFIC	ARINC 429

## 1.5 Part Numbers

### 1.5.1 ST3400 Part Number

Part number ST3400-00x is the standard version of the ST3400. The –dash number indicates product variations

-0xx Certified for Class A or B installations

-1xx Certified for Class B installation only

”Minor variations” are reserved for future product enhancements or special applications.

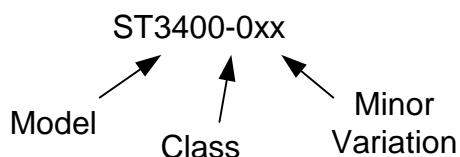

ST3400-000, CLASS A BLACK

ST3400-001, CLASS A GRAY

ST3400-100, CLASS B BLACK

ST3400-102, CLASS B GRAY

### 1.5.2 Installation Kit Part Number

An installation kit is available for the ST3400.

ST3400 INSTALLATION KIT (P/N 90130-IK)				
	Qty	Sandel P/N	Positronics P/N	Description
J1	1	32063	DD44F10JVLO	Connector 44 pin Plastic Hood/Slide Lock and Contacts
J2	1	32063	DD44F10JVLO	Connector 44 pin Plastic Hood/Slide Lock and Contacts
J3	1	32062	SD15F10JVLO	Connector 15 pin Plastic Hood/Slide Lock and Contacts

## 1.6 License Requirements

None.

## 1.7 Technical Standard Order Stipulation

The following stipulation as presented is required by the federal Aviation Administration for articles approved under Technical Standard Order. This statement does not preclude multiple installation and operational approvals in regard to specific aircraft make, model, or type:

**The conditions and tests required for TSO approval of this article are minimum performance standards. It is the responsibility of those installing this article either on or within a specific type or class of aircraft to determine that the aircraft installation conditions are within the TSO standards. TSO articles must have separate approval for installation in an aircraft. The article may be installed only in compliance with 14 CFR Part 43 or the applicable airworthiness requirements.**

## 1.8 Installation and Operational Approval Procedures

The Environmental Qualification Form for the ST3400 is included as an Appendix within this Installation Manual. It should be referenced to the categories appropriate to the aircraft type and environment into which the ST3400 is to be installed. The environmental category for the ST3400 should be stipulated on the STC form.

A “Functional Ground Test Procedures/Report” and an “Operational Flight Check Procedures Report” are included in an Appendix to this manual. They should be used as a basis for validating the ST3400 equipment configuration and to verify proper installation and functional performance. A permanent copy of the STC form must be filed and maintained by the installing agency. Another copy must be presented to the aircraft owner for entry into the aircraft maintenance records, as well as a copy forwarded to Sandel Avionics along with the Warranty Registration Form, to be filed after completion and installation acceptance.

If any difficulty is experienced with the functionality or operational performance of the ST3400, contact Sandel for assistance.



## 2 INSTALLATION PLANNING

The ST3400 has been designed to ensure maximum interoperability with all types avionics. Contact Sandel with any questions about interfacing to specific avionics equipment not covered in the installation drawings in this manual.

### 2.1 General Information

To simplify installation, after signals are wired to the ST3400 pins, on-screen setups are used in a post-installation procedure. Maintenance menu pages provide a function selection capability. For most FMS systems, selections are made by equipment make and model.

Refer to the installation schematics in an Appendix of this manual for details on connecting required components.

### 2.2 Allowed Sensor Configuration Matrix – Class A

#### 2.2.1 Required Sensors (Class-A)

1. Heading
2. GPS position
3. Localizer and Glideslope
4. Radar Altitude
5. Baro Rate (Vertical Speed)
6. Flaps
7. Gear (only if the aircraft has retractable gear).

#### 2.2.2 Additional Required Sensors, allowed configurations (Class-A)

Config	GPS Alt	Corr. Baro Alt	Press. Alt	OAT
1	x	x		x
2	x		x	
3		x		x

(Item shown blank not required)

Contact factory for configurations other than those listed.

### 2.3 Allowed Sensor Configuration Matrix – Class B

#### 2.3.1 Required Sensors (Class-B)

1. Heading
2. GPS position

### 2.3.2 Additional Required Sensors, allowed configurations (Class-B)

Config	GPS Alt	Corr. Baro Alt	Baro Rate (VS)	OAT
1	x			
2		x	x	x

(item shown blank not required)

Contact factory for configurations other than those listed.

### 2.3.3 Optional Capabilities for Class-B, needed Sensors

The following chart will assist in installation planning to add capabilities in exceedence of Class-B requirements. Without these capabilities GPWS modes 2, 4 and 5 are inoperative. With all the capabilities enabled full Class-A performance is provided, which provides autonomous GPWS protection if the GPS/FMS should fail.

Capability Desired	Sensors Needed
GPWS Mode-2 ECRT	Radar Altitude; Baro Rate (VS); Flaps; Gear <sup>2</sup> Optional
GPWS Mode-4 FITNL	Radar Altitude, Baro Rate (VS); Flaps; Gear <sup>2</sup>
GPWS Mode-5 Glideslope <sup>1</sup>	Localizer; Glideslope; Gear <sup>2</sup> and/or Flaps

<sup>1</sup> Sandel recommended.

<sup>2</sup> Req'd only on retractable-gear aircraft

## 2.4 Altitude Sources and Airdata

Airdata hookup is one of the more complex installation planning issues since there are many variations in types of airdata systems. This is particularly true of aircraft upgraded for RVSM, where the altitude source may be a new digital altimeter but the VS source may be the original airdata computer, which has been left in the aircraft to interface with other existing systems. In order to make a flexible system that requires as little additional equipment as possible, the ST3400 supports separate selection of sources for Altitude, Vertical Speed, and OAT. Please pay careful attention this fact when planning installation. See section 2.4.1 Airdata System Block Diagram.

ST3400 software 1.05 and earlier requires Corrected Barometric Altitude for either Class-A or Class-B installations. ST3400 software 2.00 and later supports GPS altitude or Corrected Barometric Altitude, or both. If both are supplied CBA is used as a backup to GPS altitude if available. See the installation diagrams for a list of approved receivers which can supply GPS altitude to the ST3400

For Class-A, at a minimum Barometric Vertical Speed and Barometric Altitude (either corrected or uncorrected) is required. This is used for the classic GPWS portion of the alerting system, such as mode-1 “Excessive Descent Rate” etc.

For Class-B, if GPS altitude is used, no other source of altitude is required; i.e. airdata is not required.

### 2.4.1 Airdata System Block Diagram

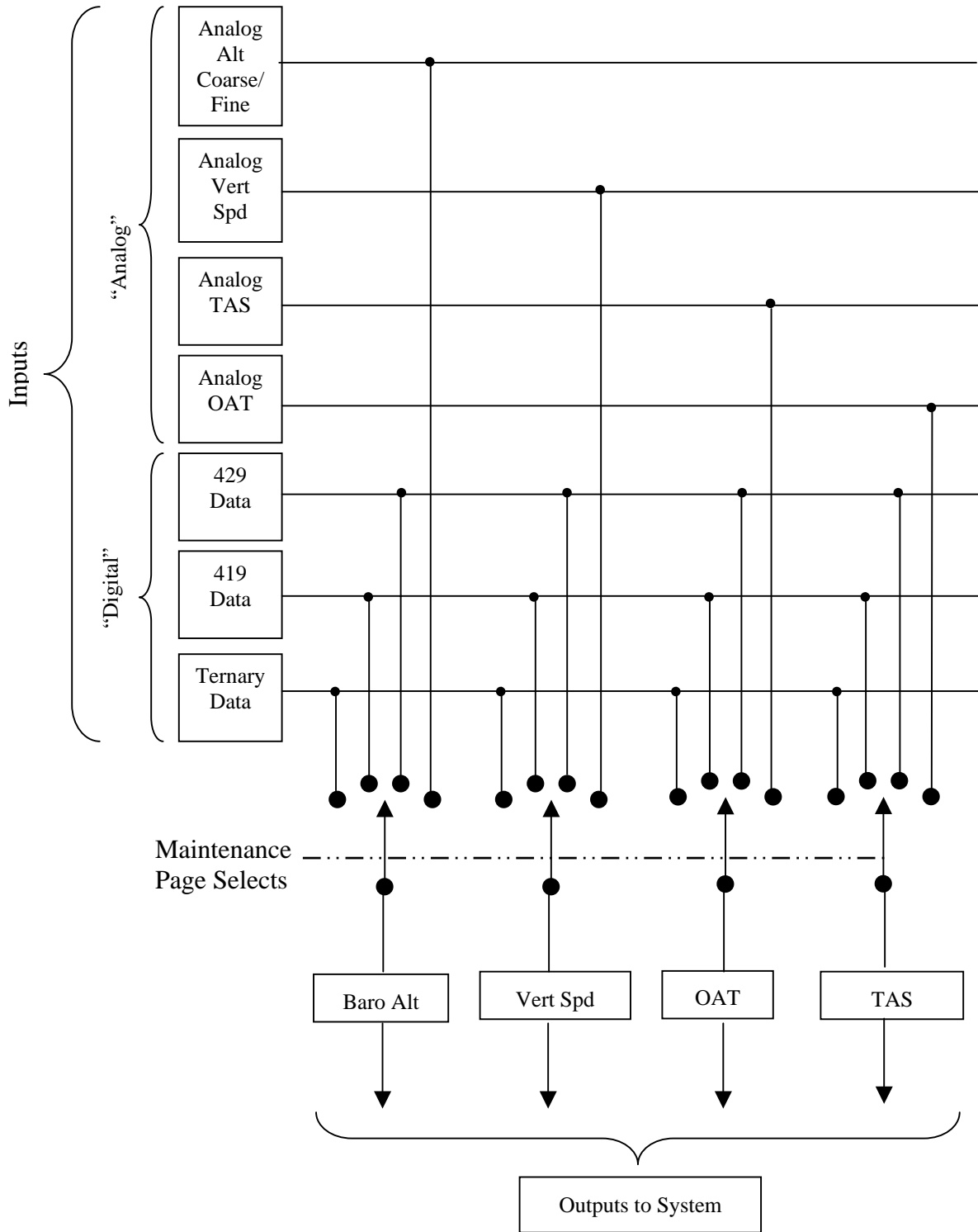

## 2.4.2 OAT Requirements

If Corrected Barometric Altitude is used as an input to the system (see above), a source of OAT is required. This is used to compensate for cold weather errors in the altitude readings. At extremely cold temperature these errors can be in excess of a thousand feet.

The source of OAT can be internal (a probe connected to the ST3400) or from the airdata system. Most digital airdata systems provide, and the ST3400 can accept digital OAT. If this data is not supplied or an analog airdata system is used, an OAT probe is connected directly to the ST3400 to provide OAT.

NOTE: The internal OAT probe is only supported in ST3400 software version 2.00 or later.

## 2.5 Pre-installation Planning

The installation planning cycle is summarized as follows:

1. Determine the desired functional characteristics for the installation.
2. Compile an equipment list for the aircraft.
  - For Class-A installations ensure the radar altimeter model provides an acceptable 2000' or 2500' maximum altitude.
  - GPS altitude data from approved receivers may be used to supply altitude. See above discussion of "altitude sources"
  - Airdata may be required. See above discussion of "altitude sources"
  - See above discussion of "OAT" above to determine the requirement for OAT probe.
  - If the desired equipment is not listed in the installation manual diagrams, contact Sandel for interoperability
3. Review the installation considerations given in the Installation Considerations section of this manual.
4. Study the installation drawings to determine a basic interconnect scheme and check for conflicts.
5. Develop the specific wiring diagrams unique to the aircraft.
6. Assemble required tools. Recommended crimp tools are given in the following table.

Recommended Crimp Tools					
		High Density 22-28 AWG		Standard Density 20-24 AWG	
	Hand Crimping Tool	Positioner	Insertion/ Extraction Tool	Positioner	Insertion/ Extraction Tool
Military P/N	M22520/2-01	M22520/2-09	M81969/1-04	M22520/2-08	M81969/1-02
Positronic	9507	9502-3	M81969/1-04	9502-5	M81969/1-02
ITT Cannon	995-0001-584	995-0001-739	N/A	995-0001-604	980-2000-426
AMP	601966-1	601966-6	91067-1	601966-5	91067-2
Daniels	AFM8	K42	M24308/18-1	K13-1	M24308/1-02
Astro	615717	615725	M81969/1-02	615724	M81969/1-02

## 2.6 Post Installation Procedures

Post installation procedures are summarized as follows:

1. Prior to power-up, review correct wiring by using industry accepted ohmmeter and voltage checks. Pay particular attention to presence of +28V on only the correct pins; 0 ohm resistance check on ground pins to airframe ground; and presence of inverter 400Hz (if used) only on the appropriate pins.
2. Review any special items particular to the subject aircraft installation.
3. Power up the ST3400 in maintenance mode and sequentially access each maintenance page to select the installed equipment.
4. Check proper cooling airflow:
  - A. Allow the unit to operate for 30 minutes.
  - B. Check the internal temperature readout on the appropriate maintenance page for an approximate temperature rise (approximately 10°C or 18°F over ambient).
5. Perform Ground Test procedures.
6. Perform Flight Test procedures if required.

THIS PAGE INTENTIONALLY LEFT BLANK

## 3 INTERFACE FUNCTIONS

### 3.1 Dual Inputs

The ST3400 contains two sets of inputs for each equipment type; for instance, there are two sets of heading inputs. In general (with some exceptions) the “primary” inputs are on P1 and the “secondary” inputs are on P2. Secondary inputs are always optional.

The ST3400 does not contain any internal comparator functions to compare the two sets of inputs. However, it will revert to the secondary input if the primary input flags or fails. This feature may be helpful to improve the system reliability of an aircraft installation. If the #1 inputs fails (such as FMS1 failure) the #2 input will become operational within 5 seconds of the failure; typically within 2 seconds.

### 3.2 Power

The primary two-wire power is 28 volt dc on J-3 and is supplied from the aircraft avionics buss through a circuit breaker. Ground is provided on J-3 and should be attached to an approved airframe ground.

Two 26 volt 400hz excitation inputs are available, if required. One is located on J-1 and the other on J-2. They are labeled as inverter-1 and inverter-2. All signals on J-1 that require excitation must use the same excitation as the inverter-1 input. All signals on J-2 (if used) that require excitation must use the same excitation as the inverter-2 input. If the installation of the ST3400 does not use any XYZ (ARINC407) signal sources, the inverter inputs are not required and should be grounded.

### 3.3 External Annunciators

Optional external annunciator lamp discrete outputs are available to drive TAWS INH, FLAP OVRD, G/S OVRD, CAUT, WARN, annunciators on J-3. A 6<sup>th</sup> annunciator output can be selected to be either TCAS INH (activates on either Caution or Warning), GPWS FAIL which duplicates the on-screen GPWS FAIL annunciation, TCAS IND which is discrete feedback to TCAS processors when the ST3400 is used as the primary TCAS indicator, or AUDIO ENA which may be used to activate a relay whenever ST3400 audio is present, including maintenance test audio.

TAWS INH is a switch /annunciator and performs the same function as the on-screen TAWS INHIBIT function. FLAP OVRD is a switch /annunciator and performs the same function as the on-screen FLAP OVRD function. G/S OVRD is a switch /annunciator and performs the same function as the on-screen G/S OVRD function.

These circuits are capable of sinking a maximum of 250 milliamps to ground and can drive incandescent lamps. Dimming of the external annunciators is accomplished by sourcing the annunciators from the aircraft day/night bus.

Proper labeling and color must be followed if the external lamp option is used.

EXTERNAL ANNUNCIATORS		
Annunciator	Color	Lamp Description
<b>WARN</b>	RED	Same as on-screen Red Warning
<b>CAUT</b>	AMBER	Same as on-screen Amber Caution
<b>TAWS INH</b>	AMBER	Same function as on-screen TAWS INH annunciation
<b>FLAP OVRD</b>	AMBER	Same function as on-screen FLAP OVRD annunciation .
<b>G/S OVRD</b>	AMBER	Same function as on-screen G/S OVRD annunciation.
<b>GPWS FAIL</b>	AMBER	Same function as on-screen GPWS FAIL annunciation

### 3.4 Flaps

The ST3400 has provisions on J-2 for Flaps In Landing Configuration input. This is obtained from either a discrete input (Flaps Down) Arinc 429 label 270 source, or XYZ. This input is required for Class A and recommended for Class B.

Flaps input is required for Class A compliance and is recommended for Class B. Note that for Class-A if flaps are misconfigured to 'NONE' a GPWS FAIL indication will appear on the display.

Configuration is performed in the Maintenance Menu pages given in the Setup Procedures section of this manual. If the installation aircraft uses flaps for normal takeoff, ensure that this input triggers in landing configuration not in takeoff configuration

### 3.5 Landing Gear

Landing Gear Position input is required for Class A compliance and is recommended for Class B (if aircraft is retractable gear).

The ST3400 has provisions on J-2 for Gear Down input discrete to indicate that the gear is in the "DOWN" position.

The configuration is performed in the Maintenance Menu pages given in the Setup Procedures section of this manual. If the system is installed in an aircraft without a retractable landing gear, select "NONE" on maintenance page configuration item.

### 3.6 Autopilot

The ST3400 has provisions on J-2 for discrete input signals to obtain an indication of Autopilot Engage. The input signals are used to modify alerting characteristics.

The Autopilot Engaged discrete is configurable for either valid High (<14vdc off, >14vdc on) or valid Low (<3.5vdc on, >3.5vdc off).

The configuration is performed in the Maintenance Menu pages given in the Setup Procedures section of this manual.

### 3.7 Audio Panel

The Audio output is required for Class A and Class B compliance. The ST3400 has provisions for low level audio output located on J1-30 and simultaneous direct speaker audio on J1-15 for units with mod-A. The LL audio output must interface to the un-switched audio input of the aircraft audio system.

The audio output produces the GPWS “whoop-whoop” as well as human voice callouts. The LL audio output is the ‘master level’ and the ‘speaker audio’ has a separate adjustment on the installation maintenance page to trim the speaker level relative to the headphone level. If after adjustment the available speaker audio level is insufficient, turn up the master audio level at the ST3400 and make a corresponding reduction in the LL audio level at the headphone amplifier.

The overall level is based on the nominal and maximum audio level configuration. The maximum audio level is a maximum of four (4) times the nominal audio level. The audio level automatically ranges from the Nominal Audio Level to the Maximum Audio Level as the aircraft airspeed increases.

### 3.8 GPS/FMS

A Global Positioning System (GPS) or Flight Management System (FMS) input is required for both Class A and Class B compliance.

Note: This system must be GPS-based system and meet TSO-C129a or C-145 requirements. GPS is used for lateral positional and to display flight plan information. In certain installations it may also used for vertical position.
--

The ST3400 has provisions for one or two simultaneous GPS ARINC 429 receiver ports. The primary port is located on J-1 and the optional secondary port is located on J-2. The receiver ports are configurable in the Maintenance Menu pages for High or Low speed ARINC. A list of supported Labels is given in an Appendix of this manual.

### 3.9 Radar Altimeter

The Radar Altimeter input is required for Class A compliance and is recommended for Class B.

The ST3400 has provisions for one Radar Altimeter input. The primary input is located on J-1. (With the exception of the RA FAIL input, see below). Radar Altimeter input may be from an ARINC 429 or DC Analog sources. The Radar Altimeter input is used to obtain Height Above Terrain for GPWS alerting. The ST3400 will support 2000 ft Radar Altimeters such as the Collins ALT-50A in either Class A or Class B installations. The radar altimeter may be connected using its analog outputs or through an existing analog-to-429 converter.

The ST3400 will accept analog ALT50/55, ARINC 552, KRA10 and other analog type inputs.

The RA1 FAIL input is located on J2. The input is normally connected to the RA indicator power at either the RA R/T unit or the RA indicator. When < 10VDC this signal will cause the RA input to assume the FAIL state regardless of the state of the signal or Valid input.

The radar altimeter always produces a '500' audio callout during descent to landing. Optionally the installer may select any or all of the following additional audio callouts when the aircraft is in a descent in the landing configuration:

400', 300', 200', 100', 50', 40', 30', 20', 10'

An additional discrete input is available for connection to a Decision Height setter. The ST3400 will provide an audio callout "MINIMUMS" when Decision Height input is asserted.

Note: The Radar Altimeter model must be able to provide information to the ST3400 through at least 2000'. Check the Radar Altimeter installation manual
---

### 3.10 Heading System

Heading input is required. Heading information is used to obtain magnetic direction of the aircraft for use by the RMI. The Heading information may be available from many sources, such as AHRS, INS, and Slaved Compass systems.

The ST3400 has provisions for up to two simultaneous Heading System input ports. The primary input port is located on J-1 and the optional port is located on J-2. Either one may be from an ARINC 429 or XYZ (ARINC 407) source configurable in the Maintenance Menu pages. A list of supported Labels is given in an Appendix of this manual.

The XYZ (ARINC 407) is dependent on availability of 26VAC excitation for proper operation. In addition, an optional Gyro Valid input (DC level sensitive) is provided if available from the gyro either valid High or Low. If no valid is provided by the Gyro then valid NONE is selected.

If after 10 seconds no valid XYZ signal is being received an on-screen error message is generated

### 3.11 ADF Receiver

The input of the ADF information is optional and not required for the Class A or Class B TAWS compliance. It is used in an application where the ST3400 is used to replace an existing RMI and ADF operation is desired or required.

The ST3400 has provisions for up to two simultaneous ADF Receiver ports. The optional primary port is located on J-1 and the optional secondary port is located on J-2. Either one may be from an ARINC 429, DC Sin/Cos, or XYZ (ARINC 407) sources. For analog DC Sin/Cos or XYZ receivers, an optional ADF Valid input is supported if the receiver supplies a compatible signal

### 3.12 NAV Receiver and Glideslope

This information is required for Class A compliance and recommended for Class B. The ST3400 has provisions for up to two simultaneous VHF Navigation and Glideslope receiver ports; the primary receiver port on J-1 and the optional secondary receiver port on J-2. Either one may be from an ARINC 429 or Analog sources. The NAV input is used for the VOR bearing pointer. The Localizer and Glideslope inputs are used for GPWS mode-5 alerting.

When an ARINC 429 receiver system is used, the same input will carry either VOR or ILS data depending on the receiver tuning. See the appropriate manufacturers manual to confirm the information from the navigation and Glideslope receivers.

Standard analog inputs for Glideslope deviation, Glideslope flag status, and Composite Nav information are also provided and may be used instead of the ARINC 429. If Composite Nav is used, these inputs are not on the same pins as the Arinc inputs and are both located on P2.

An additional discrete input is available for Back Course from the HSI, which is used to automatically disable Glideslope alerting while on a Back Course.

Note: The composite Nav input also decodes localizer when tuned.
--

### 3.13 Air Data Computer

See above discussion of “Altitude Sources”. Air Data Computer input is required for Class A installations and Class-B installations without GPS altitude. For Class-B installations with GPS altitude airdata may be used as a backup altitude and VS source and is optional.

For Class-A installations using GPS altitude, the airdata system must at least supply Vertical Speed and barometric altitude, either corrected or uncorrected.

For Class-A installations without GPS altitude, the airdata system must supply Vertical Speed, Corrected Baro Altitude, and OAT. If OAT is not supplied by the airdata system directly, a compatible OAT probe may be wired directly to the ST3400.

The ST3400 has provisions for up to two simultaneous Air Data Computer ports depending on model. The primary receiver port on J-1 and the optional secondary receiver port on J-2. Primary Airdata may be from an ARINC 429, Manchester or ARINC 565 secondary analog output source and Secondary Airdata maybe 429 or Manchester only, no #2 Airdata Analog input available.

### 3.14 OAT Probe

The ST3400 supports a single directly connected OAT probe to accommodate airdata computers which supply Corrected Baro Altitude to the ST3400 but do not supply OAT. See installation diagrams for information about compatible probes. OAT is required only when using Corrected Barometric Altitude. If GPS Altitude is used, no OAT probe is required.

### **3.15 Traffic**

The ST3400 supports Traffic input via single ARINC 429 High Speed Input on software version 3.00 and above. Traffic may be overlaid on terrain or displayed on a separate TFC screen without terrain.

Some remote traffic processors may require remote switches, see Traffic interface drawings in this manual for these requirements.

If an existing ST3400 installation is being upgraded to display Traffic, please contact the factory for a software key to enable the traffic display.

### **3.16 ST3400 Interlink**

Reserved for Future use. In dual installations it is recommend to connect.

### **3.17 Uploading Equipment**

A USB interface is available on the front of the ST3400 to upload system software, terrain data, airport data, and configuration data into memory and to download configuration data from memory.

Data is loaded from a PC or laptop computer with Microsoft Windows 98 (or later) operating system software to the ST3400. Drivers, the loader program, and loading instructions are supplied with the applicable software or data.

### **3.18 Display Dimming**

The ST3400 screen dimmer is controlled from the Pilot's Menu using the "M" button. The display and push-button LED luminance levels are coordinated. Units with Mod-A have selectable auto/manual dimming. Units without Mod-A have manual dimming only.

External annunciator dimming may be accomplished using the existing aircraft day/night buss by connecting the high-side of the annunciator lamps day/night buss.

### **3.19 Windshield Wipers**

A discrete input signal is provided to increase the audio level to allow the flight crew to hear the aural alerts during high noise conditions.

The Auto Audio Level Increase discrete may be connected to windshield wiper logic to automatically increase the audio level when using high noise windshield rain removal equipment during heavy rain.

Note: This discrete input is a shared function with RA2 FAIL. If the aircraft installation has dual radar altimeters, please contact Sandel for information to access the windshield wiper function through another pin.





## 4 INSTALLATION

The ST3400 should be installed in accordance with standards established by the customer's installing agency, and existing conditions as to unit location and type of installation.

### 4.1 Unpacking and Inspecting Equipment

Exercise extreme care when unpacking the equipment. Make a visual inspection of the unit for evidence of damage incurred during shipment. If a claim for damage is made, save the shipping container to substantiate the claim. The claim should be promptly filed with the carrier. It would be advisable to retain the container and packaging material after all equipment has been removed in the event that equipment storage or reshipment should become necessary.

### 4.2 Cooling Considerations

The ST3400 contains its own ventilation fan for internal component cooling and does not require a forced air cooling system. However, it is extremely important that the perforated area at the four corners (air intakes) be kept clear of any objects which would restrict the inflow of air at cabin ambient temperature.

Cooling should be verified in the post-installation checkout by monitoring the temperature on the Diagnostics 1 page.

For additional cooling or special requirements, air from an external avionics blower may be directed near the corner air inlets.

In helicopter installations it may be desirable to introduce a small amount of cooled (air conditioner) air into the avionics bay if it is completely sealed. In these installations it is not uncommon for the internal ambient temperature of the avionics bay to exceed the ratings of the equipment if cooling air is not supplied.

### 4.3 Mechanical Installation Considerations

#### 4.3.1 Instrument Location in the Cockpit

The Sandel ST3400 is a direct replacement for a currently installed RMI. Installation should conform to customer requirements and airworthiness standards affecting the location and type of installation.

#### 4.3.2 Assembly and Mounting Instructions

Refer to the ST3400 Installation Diagrams for specific assembly and mounting instructions and appropriate notes.

## 4.4 Electrical Installation Considerations

The installing agency fabricates and supplies all wiring harnesses. Refer to the ST3400 Interconnect Wiring Diagrams for detailed wiring information and appropriate notes.

Refer to the Functional Pinout Descriptions for explanations of pin functions.

1. The length and routing of wires must be carefully planned before starting the installation.
  - Avoid sharp bends in the harness.
  - Do not locate the harness near aircraft controls.
  - Observe all recommended wire sizes and types and subscribe to appropriate FAR Parts 23, 25, 27, and 29, as well as AC 43.13-1(B) and -2(A).
2. MIL-C27500 shielded wire and MIL-W-22759 single conductor wire is recommended. The use of ferrules or grounding blocks for signal ground and digital ground returns is satisfactory, however, each ground return must be electrically separated.
3. In order to ensure optimum performance, the ST3400 and associated wiring must be kept a minimum of three feet from high noise sources and not routed with cables from high power sources.
4. Prior to installation, verify proper wiring by completing a point-to-point continuity check of the wiring harness.
5. Use the Functional Pinout Descriptions to determine installation requirements.
6. Ground Bonding. In order to assure installation characteristics match the DO-160 RF and Lightning test conditions, ensure that two ground wires of at least the recommended size are installed in accordance with the installation drawings and these wires are connected to a bonded aircraft ground.
7. Power Wiring. To assure that the ST3400 will operate properly down to its rated minimum input voltage, ensure that two power wires of at least the recommended size are connected in accordance with the installation drawings.

## 4.5 Connector P1

For electrical characteristics, see the table in section 4.9 by referencing the signal type indicated in *italics*. Signal types enclosed in parentheses indicate functionality that is reserved.

Pin #		Name	Signal Type (dependent on maintenance page selection)
	16	<b>Inverter Exc.</b>	In <i>Inverter</i> Note: May be same or different than P2-16 inverter source. 26Vac Excitation for items on connector P1
1		<b>Shield Gnd</b>	
	31	<b>FMS1A Primary</b>	In <i>A429</i> <i>(RS422)</i> <i>(RS232)</i> A side 429 + side 422 Ground side
	17	<b>FMS1B Primary</b>	In <i>A429</i> <i>(RS422)</i> <i>(RS232)</i> B side 429 - side 422 Rx
2		<b>Radalt1A</b>	In <i>A429</i> <i>RadAlt</i> A side 429 Analog DC+ [ALT 50/55, ARINC 552, RT220/300, RT200]
	32	<b>Radalt1B</b>	In <i>A429</i> <i>RadAlt</i> B side (429) Analog DC- [ALT 50/55, ARINC 552, RT220/300, RT200]
	18	<b>Radalt1 Valid</b>	In <i>Discrete Valid</i> Discrete, Note: Not used when 429 is data source
3		<b>Hdg1A</b>	In <i>A429</i> <i>A407</i> A side 429 Synchro X [Z grounded]
	33	<b>Hdg1B</b>	In <i>A429</i> <i>A407</i> B side 429 Synchro Y [Z grounded]
	19	<b>Hdg1 Valid</b>	In <i>Discrete Valid</i> Hdg Analog, Note: Not used when 429 is data source.
4		<b>ADF1A</b>	In <i>A429</i> <i>DC Sin</i> <i>A407</i> A side 429 DC Sine Synchro X [Z grounded]
	34	<b>ADF1B</b>	In <i>A429</i> <i>DC Cos</i> <i>A407</i> B side 429 DC Cosine Synchro Y [Z grounded]
	20	<b>ADF1 DC Ref</b>	In <i>ADF Ref</i> ADF DC, Note: Not used when 429 or XYZ is data source.
5		<b>ADF1 Valid</b>	In <i>Discrete Valid</i> ADF Discrete, Note: Not used when 429 is data source
	35	<b>Nav1A</b>	In <i>A429</i> <i>(RS422)</i> <i>(RS232)</i> Note: For composite inputs see P2-42 A side 429 + side 422 Ground side
	21	<b>Nav1B</b>	In <i>A429</i> <i>(RS422)</i> <i>(RS232)</i> Note: For composite inputs see P2-42 B side 429 - side 422 Rx

**P1 Connector (continued from previous page)**

Pin #		Name	Signal Type (dependent on maintenance page selection)	
6		<b>GS1 LL Flag In+</b>	In <i>GS Flag</i>	Differential pair to pin 36 Note: For use with external SUPERFLAG see installation drawing for series resistor required.
	36	<b>GS1 LL Flag In-</b>	In <i>GS Flag</i>	Differential pair to pin 6.
	22	<b>GS1 LL Dev In +FLY DOWN</b>	In <i>GS</i>	Differential pair to pin 7. Polarity: + indicates above glideslope, fly-down indication.
7		<b>GS1 LL Dev In +FLY UP</b>	In <i>GS</i>	Differential pair to pin 22. Polarity: + indicates below glideslope, fly-up indication
	37	<b>Airdata1A</b>	In <i>A429/419 (R422) (R232) A407</i> Manchester	A side 429/419 + side 422 Ground side AC resolver Fine Sine Altitude Synchro X Fine Altitude High
	23	<b>Airdata1B</b>	In <i>A429/419 (R422) (R232) A407</i> Manchester	B side 429/419 - side 422 Rx AC resolver Fine Cosine Altitude Synchro Y Fine Altitude Low
8		<b>Alt1 / VS1 Gnd</b>	In <i>A429/419 (R422) (R232) (A407) Alt DC Coarse</i>	Note: Differential signals paired with pin 39. A side 429/419 + side 422 Ground side Synchro X Ground at source
	38	<b>VS1 Signal</b>	In <i>VS Sig</i>	DC voltage - 5V to + 5V = -10,000 to +10000 FPM
	24	<b>VS1 Ref-</b>	In <i>VS Ref</i>	Note: -12Vdc excitation reference
9		<b>VS1 Ref+</b>	In <i>VS Ref</i>	Note: +12Vdc excitation reference
	39	<b>Alt1 DC Coarse</b>	In <i>A429/419 (R422) (R232) (A407) Alt DC Coarse</i>	Note: Differential signals paired with pin 8. B side 429/419 - side 422 Rx Synchro Y High side
	25	<b>TAS1 Sig</b>	In <i>TAS Sig</i>	
10		<b>TAS1 Ref</b>	In <i>TAS Sig</i>	
	40	<b>Airdata1 Valid</b>	In <i>Discrete Valid</i>	ADC Analog, Note: Not used when 429 is data source.
	26	<b>FMS1 A Secondary</b>	(In) <i>(A429) (R422) (R232) (A407)</i>	n/c A side 429 + side 422 Ground side Synchro X
11		<b>FMS1 B Secondary</b>	(In) <i>(A429) (R422) (R232) (A407)</i>	n/c B side 429 - side 422 Rx Synchro Y

**P1 Connector (continued from previous page)**

Pin #			Name	Signal Type (dependent on maintenance page selection)	
		41	<b>Flaps-X / Spare1A</b>	(In) A429/419 (R422) (R232) (A407) (A568)	n/c A side 429/419 + side 422 Ground side Synchro X Data
	27		<b>Flaps-Y / Spare1B</b>	(In) A429/419 (R422) (R232) (A407) (A568)	n/c B side 429/419 - side 422 Rx Synchro Y Clk
12			<b>N/C</b>	In A568	n/c Sync
		42	<b>429 Out A</b>	Out A429	A Side - Alert output to FDR - High Speed (100Kbps)
	28		<b>429 Out B</b>	Out A429	B Side - Alert output to FDR - High Speed (100Kbps)
13			<b>RS232TxD</b>	(Out (R232)	
		43	<b>n/c</b>	In Discrete	<b>Factory use only DO NOT CONNECT</b>
	29		<b>OAT Probe</b>	In A575	Connect other lead to pin-1 GROUND. Excitation
14			<b>n/c</b>	n/c	
		44	<b>n/c</b>	n/c	
	30		<b>Audio LL Out</b>	Out Audio LL	Low Level Audio output, requires external amplifier
15			<b>Speaker Audio Out</b>	Out  Audio Spkr	Clone of audio from Audio1 which has the capability of driving 8 ohm speaker directly. Volume separately trimmed with respect to LL audio, which acts as master.

**4.5.1 View of Mating Connector to P1**

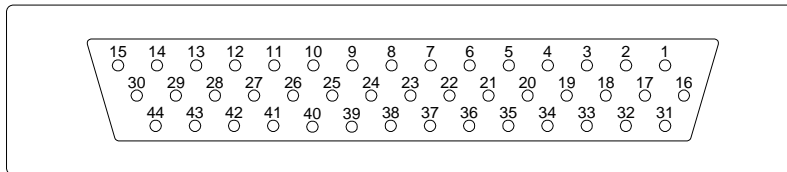

Outside View  
(Mating Connector)

## 4.6 Connector P2

For electrical characteristics, see the table in section 4.9 by referencing the signal type indicated in *italics*. Signal types enclosed in parentheses indicate functionality that is reserved.

Pin #		Name	Signal Type (dependent on maintenance page selection)
	16	<b>Inverter Exc.</b>	In <i>Inverter</i> Note: May be same or different than P2-16 inverter source. 26Vac Excitation for items on connector P1
1		<b>Shield Gnd</b>	
	31	<b>FMS2A Primary</b>	In A429 <i>(RS422)</i> <i>(RS232)</i> A side 429 + side 422 Ground side
	17	<b>FMS2B Primary</b>	In A429 <i>(RS422)</i> <i>(RS232)</i> B side 429 - side 422 Rx
2		<b>TCAS A</b>	In A429 <i>(RS232)</i> A side 429 Ground Side
	32	<b>TCAS B</b>	In A429 <i>(RS232)</i> B side 429 Rx
	18	<b>Decision Height Discrete</b>	In <i>Discrete Valid</i> Discrete Open/Gnd or Open/+28VDC
3		<b>Hdg2A</b>	In A429 A407 A side 429 Synchro X [Z grounded]
	33	<b>Hdg2B</b>	In A429 A407 B side 429 Synchro Y [Z grounded]
	19	<b>Hdg2 Valid</b>	In <i>Discrete Valid</i> Hdg Analog, Note: Not used when 429 is data source.
4		<b>ADF2A</b>	In A429 <i>DC Sin</i> A407 A side 429 DC Sine Synchro X [Z grounded]
	34	<b>ADF2B</b>	In A429 <i>DC Cos</i> A407 B side 429 DC Cosine Synchro Y [Z grounded]
	20	<b>ADF2 DC Ref</b>	In <i>ADF Ref</i> ADF DC, Note: Not used when 429 or XYZ is data source.
5		<b>ADF2 Valid</b>	In <i>Discrete Valid</i> ADF Discrete, Note: Not used when 429 is data source
	35	<b>Nav2A</b>	In A429 <i>(RS422)</i> <i>(RS232)</i> Note: For composite inputs see P2-42 A side 429 + side 422 Ground side
	21	<b>Nav2B</b>	In A429 <i>(RS422)</i> <i>(RS232)</i> Note: For composite inputs see P2-42 B side 429 - side 422 Rx

**P2 Connector (continued from previous page)**

Pin #			Name	Signal Type (dependent on maintenance page selection)	
6			<b>GS2 LL Flag In+</b>	In <i>GS Flag</i>	Differential pair to pin 36 Note: For use with external SUPERFLAG see installation drawing for series resistor required.
		36	<b>GS2 LL Flag In-</b>	In <i>GS Flag</i>	Differential pair to pin 6.
	22		<b>GS2 LL Dev In +FLY DOWN</b>	In <i>GS</i>	Differential pair to pin 7. Polarity: + indicates above glideslope, fly-down indication.
7			<b>GS2 LL Dev In +FLY UP</b>	In <i>GS</i>	Differential pair to pin 22. Polarity: + indicates below glideslope, fly-up indication
		37	<b>Digital Airdata 2A</b>	In <i>A429 /419 (R422) (R232) Manchester</i>	A side 429/419 + side 422 Ground side High
	23		<b>Digital Airdata 2B</b>	In <i>A429 /419 (R422) (R232) Manchester</i>	B side 429/419 - side 422 Rx Low
8			<b>Spare Analog 1</b>	In	
		38	<b>Spare Analog 2</b>	In	
	24		<b>Flaps Ovrđ</b>	In	Discrete Open/Gnd
9			<b>GS Ovrđ</b>	In	Discrete Open/Gnd
		39	<b>Pressure Altitude 1 Analog</b>	In	Pressure Altitude 0.25 VDC/1Kft or 0.3175 VDC/1K ft
	25		<b>Spare Analog 3</b>	In	
10			<b>VS1 Rate (CIC)</b>	In	10 VDC +/-5 VDC, 0.5 VDC/1K ft
		40	<b>Backcourse (BC) Discrete</b>	In <i>Discrete Valid</i>	Discrete Open/Gnd or Open/+28VDC.
	26		<b>FMS2 A Secondary</b>	(In) <i>(A429) (R422) (R232)</i>	n/c A side 429 + side 422 Ground side
11			<b>FMS2 B Secondary</b>	(In) <i>(A429) (R422) (R232)</i>	n/c B side 429 - side 422 Rx

**P2 Connector (continued from previous page)**

Pin #			Name	Signal Type (dependent on maintenance page selection)
		41	<b>Spare</b>	(In) (A429) n/c (R422) A side 429 (R232) + side 422 (A407) Ground side (A568) Synchro X Data
	27		<b>Spare</b>	(In) (A429) n/c (R422) B side 429 (R232) - side 422 (A407) Rx (A568) Synchro Y Clk
12			<b>Spare2C</b>	(In) (A568) n/c Sync
		42	<b>Nav1 Composite</b>	In A710, A711 VOR Bearing and Localizer Deviation input. Used when ARINC 429 data is not used
	28		<b>Nav2 Composite</b>	In A710, A711 VOR Bearing and Localizer Deviation input. Used when ARINC 429 data is not used
13			<b>RA1 FAIL</b>	In Discrete Valid If RA1 configured: <14VDC indicates RA 1 Fail
		43	<b>Audio Increase</b>	In Discrete Valid Activates audio level increase.
	29		<b>AP Engage</b>	In Discrete Valid
14			<b>Gear Down</b>	In Discrete Valid
		44	<b>Flaps Ldg</b>	In Discrete Valid Indicate flaps are in landing (not takeoff) configuration
	30		<b>429A Interlink</b>	Out A429 For dual installations to feed cross-side system A side 429
15			<b>429B Interlink</b>	Out A429 For dual installations to feed cross-side system B side 429

**4.6.1 View of Mating Connector to P2**

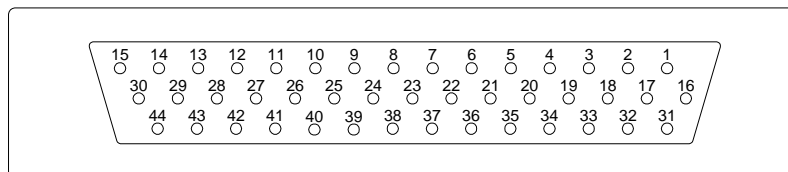

Outside View  
(Mating Connector)

## 4.7 P3 Connector

For electrical characteristics, see the table in section 4.9 by referencing the signal type indicated in *italics*. Signal types enclosed in parentheses indicate functionality that is reserved.

Pin #	Name	Signal Type (dependent on maintenance page selection)
1	<b>Aircraft Pwr</b>	In <i>Power</i>
9	<b>Aircraft Pwr</b>	In <i>Power</i>
2	<b>n/c</b>	n/c
10	<b>n/c</b>	n/c
3	<b>Aircraft Ground</b>	In System Ground
11	<b>Aircraft Ground</b>	In System Ground
4	<b>GS OVRD Lamp</b>	(Out) <i>(Open Drain)</i>
12	<b>FLAPS OVRD Lamp</b>	(Out) <i>(Open Drain)</i>
5	<b>n/c</b>	In <b>Factory use only DO NOT CONNECT</b>
13	<b>TAWS INH</b>	In <i>Discrete Valid</i> Optional external TAWS INH switch
6	<b>Lamp Test</b>	In <i>Discrete Valid</i> Optional external enunciator test
14	<b>Warning Lamp</b>	Out <i>Open Drain</i> Optional
7	<b>Caution Lamp</b>	Out <i>Open Drain</i> Optional
15	<b>TAWS INH Lamp</b>	Out <i>Open Drain</i> Optional
8*	<b>Selectable Discrete*</b>	(Out) TCAS INH (TAWS Warn or Caution); -or- GPWS FAIL ; -or- TCAS INDICATOR discrete to TCAS-II -or- AUDIO ENABLE relay drive <i>(Open Drain) Selectable on SYSTEM maintenance page</i>

\* Note: All discrete outputs sink 50ua of current when off. If used as TCAS INH to a TCAS processor, this connection may require an external 30k-50k pullup resistor in order for the discrete input of the TCAS to be at the proper 'high' (unasserted) voltage. If necessary, check with a voltmeter during installation.

### 4.7.1 View of Mating Connector to P3

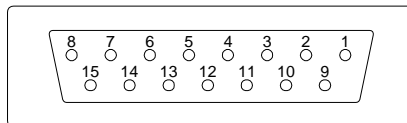

Outside View  
(Mating Connector)

## **4.8 P4 Connector**

Accepts ST3400 Configuration Module.

Note: Configuration Module active in software 2.10 and above. Configuration module may be left connected to ST3400 in prior software versions but will not store data.

The ST3400 will may be operated with or without a configuration module connected. If no configuration module is present the pilot will receive an advisory message.

## 4.9 Signal Type Electrical Characteristics

Inputs			
Signal Type	Nom Range	Absolute Max	Z ( $\Omega$ – Power Off)
A429	+/- 5Vdc	100Vdc	>100K
A568	0 / +10Vdc	100Vdc	>100K
RS232	+/- 10Vdc	100Vdc	>100K
RS422	+/- 5Vdc	100Vdc	>100K
A710 (ILS)	.5Vac rms +/- 20%	70Vac	>100K
A711 (VOR)	.5Vac rms +/- 20%	70Vac	>100K
A407	0 to 11.8Vac	70Vac	>100K
A575	.5 to 2.5Vdc	5Vdc	>500K
DC Sine/Cosine	+/- 20Vdc	100Vdc	>100K
A407 (AC Synchro)	11.8Vac rms +/- 20%	100Vdc	>100K
ADF_REF	10Vdc +/- 50%	60Vdc	>100K
Alt DC Coarse	0 to 15Vdc	100Vdc	>100K
Analog Baro Altitude	0 to 10Vdc	100Vdc	>100K
Analog Radar Altitude	0 to 30Vdc	100Vdc	>100K
Discrete Valid (High)	>14.0Vdc <sup>Note 4</sup>	60Vdc	>500K
Discrete Valid (Low)	<3.5Vdc <sup>Note 4</sup>	40Vdc	>500K
Discrete (High)	>1.2Vdc	32Vdc	50K
Discrete (Low)	<8Vdc	32Vdc	50K
GS	+/- 225mv FS	60Vdc	>300K <sup>Note 2</sup>
GS Flag	Unflagged > 225mv	60Vdc	>300K <sup>Note 2</sup>
Inverter	26Vac rms 400Hz Nom 300Hz-5000Hz Limits	200Vac	>50K
Power	+22 to +30.3Vdc <sup>Note 1</sup>	7Adc	NA
RadAlt	-.5 to +30Vdc	100Vdc	>100K
VS_Ref	0Vdc +/- 5, 15Vdc Full Scale	90Vdc	>500K
VS_Sense	0Vdc +/- 5, 23.6Vdc Full Scale	90Vdc	>500K
VS Sig	- 5 to +5Vdc = -10K to +10K FPM	30Vdc	>500K
TAS Sig	10Vdc Full Scale	90Vdc	>500K

### Signal Type Electrical Characteristics (cont.)

Outputs			
Signal Type	Nom Range	Absolute <sup>Note 3</sup> Max	Load ( $\Omega$ )
A429	+/- 5Vdc	70mAdc	2K (Minimum)
RS232	+/- 5Vdc	70mAdc	500 (Minimum)
A575	3.54 mA +/-1%	25mA	500
Audio Output (LL)	0 to 27.2V <sub>pk-pk</sub>	27.2V <sub>pk-pk</sub>	600
Audio Output (Spkr)	0 to 4 Watts Max RMS into 8 ohms	16V <sub>pk-pk</sub>	8 (inductive)
Open Drain	1 $\Omega$ or High Impedance (over current protected)	250mAdc	>350K

Notes:

1. At +28Vdc, nominal current is 1.4Adc +/- 5%, 1 minute after start up.
2. Power On Load = 60.4K. For Glideslope there may need to be a 1K load somewhere else in the system to meet the receiver load requirements. Check installation instructions for the interfaced receiver.
3. Outputs are protected against shorts to ground. Shorts to power supply may cause damage to components.
4. Discrete inputs actively pulled to 27.5v through 30k ohms when selected 'active low' or actively pulled to 0v through 30k ohms when selected 'active high' in the maintenance pages. This ensures the input is in the 'inactive' state if an external connection fails. If interfacing to discrete signals which do not supply a "hard" 0v/27.5 volt transition, any input network may be used that ensures that the discrete input pin is not within 1.0v from its nominal threshold shown in the table either in the active or inactive state.

## 5 MAINTENANCE MODE

### 5.1 Normal Mode Operation

Unless the system is started up in “maintenance mode”, it will automatically power-up in “Normal” flight operations mode.

### 5.2 Maintenance Mode

To access the Maintenance Mode, prior to applying power to the system, press and hold the [BRG 1] [BRG 2] selection buttons then apply power and wait until the Maintenance Index page is displayed. Then release these buttons.

From the maintenance mode the system normal operations can be accessed by holding the “M” button for approximately 3 seconds. This feature can be used to test or see the results of a change in maintenance page configuration. The maintenance pages can be brought back by holding the “M” button again for 3 seconds.

NOTE: WHEN DOING A FINAL TEST OF A SYSTEM MAKE SURE THE POWER HAS BEEN RECYCLED TO VERIFY CORRECT SETTINGS.

To exit the maintenance mode for normal flight operations turn off the power for 15 seconds and restart the unit normally.

THIS PAGE INTENTIONALLY LEFT BLANK

## 6 SETUP PROCEDURES

### 6.1 General

Setup procedures for the ST3400 are accessed and addressed through the Maintenance Mode.

#### 6.1.1 Accessing Maintenance Pages

The Maintenance Mode allows the operator to read and edit the factory settings and the configuration data associated with a unit. The system will use this information to configure its internal/external interfaces appropriately and save the information to a configuration file.

The first maintenance page is the Maintenance Index., This page provides a list of the subsequent pages. The maintenance index menu lists the number and title for each maintenance page.

The maintenance pages operate in either “READ” or “EDIT” mode. Read mode write-protects the configuration data. Pressing the [MODE] softkey in the maintenance index will change the mode to “EDIT” which removes the write-protection and allows changing any configuration item.

#### 6.1.2 Uploading Data or System Software

The Windows based ST3400 TAWS Loader program is used to transfer terrain data, airport data, , and configuration data to the TAWS equipment memory. The Loader communicates with the ST3400 unit via the USB Port located in the lower right corner of the front bezel.

The Loader runs on a personal computer with a USB port and Microsoft Windows 98, Windows Me, Windows 2000, or Windows NT software.

The applicable Windows Driver, Loader executable, and instructions are supplied with the software or data. The Loader only operates *when in maintenance mode*.

NOTE: As a convenience to identification System Software for units with MOD-A is marked with an ‘A’ prefix. For example, software 3.05 loads into a non MOD-A unit; software A3.05 loads into a MOD-A unit. The “A” prefix is not a significant digit in the software part number or in the software certification, i.e. A3.05 and 3.05 are considered identical for the purpose of conformity.

Incompatible software is automatically detected by the Loader and *will not load*.

#### 6.1.3 Configuration Module

The Configuration Module (CM) stores installation configurations. The physical Configuration Module is directly mounted to the rear of the instrument. Configuration module can be used when replacing an existing ST3400. Data stored in the configuration module can be copied directly to the replacement unit.

### 6.1.4 Configuration Module Status Page

“**CONFIG MODULE STATUS**” page may appear during initial turn on and programming of a unit. This page will only appear again if there is a mismatch between the configuration information saved in the Configuration Module and the ST3400. The mismatch identified with the configuration information is shown at the top of this page, along with the actions that may be taken.

The options displayed on the “**CONFIG MODULE STATUS**” page are as follows.

#### “**DISABLE CM**” (~~CM~~)

When this option is selected no stored data will be read from or written to the Configuration Module. Selecting “Disable CM” will allow the installer to go directly to the Maintenance Index page 1.

Note “~~CM~~” will appear in the upper right corner to indicate that the configuration module is not operational.

#### “**ST3400 TO CM**”:

Selecting this option will allow stored ST3400 configuration data to be written to the configuration module and stored.

**NOTE:** When selecting this option ST3400 configuration data will be written **TO** the configuration module and overwrite any existing configuration data in the Configuration Module.

#### “**CM TO ST3400**”:

Selecting this option will allow stored Configure Module data to be written to the ST3400.

**NOTE:** When selecting this option data **FROM** the configuration module will overwrite any existing configuration data in the ST3400. The configuration module is unaffected.

### 6.1.5 Tail Number

As part of the configuration, an aircraft identifier (Tail Number) should be entered on the systems settings page.

## 6.2 Maintenance Index Page

The Maintenance Index page (see Figure 6-1) is a multiple-choice list that provides an index of all other maintenance pages and allows the operator to jump to a particular page. First scroll the Cursor to point to the desired maintenance page listing using the [Up] Soft key or [Down] Soft key. The [SELECT] Soft key is then pressed to jump to this page. Once in the Maintenance pages, press the [OPER] Soft key to return to the Maintenance Index page. The [PREV] or [NEXT] Soft keys may also be used to reach a particular maintenance page sequentially.

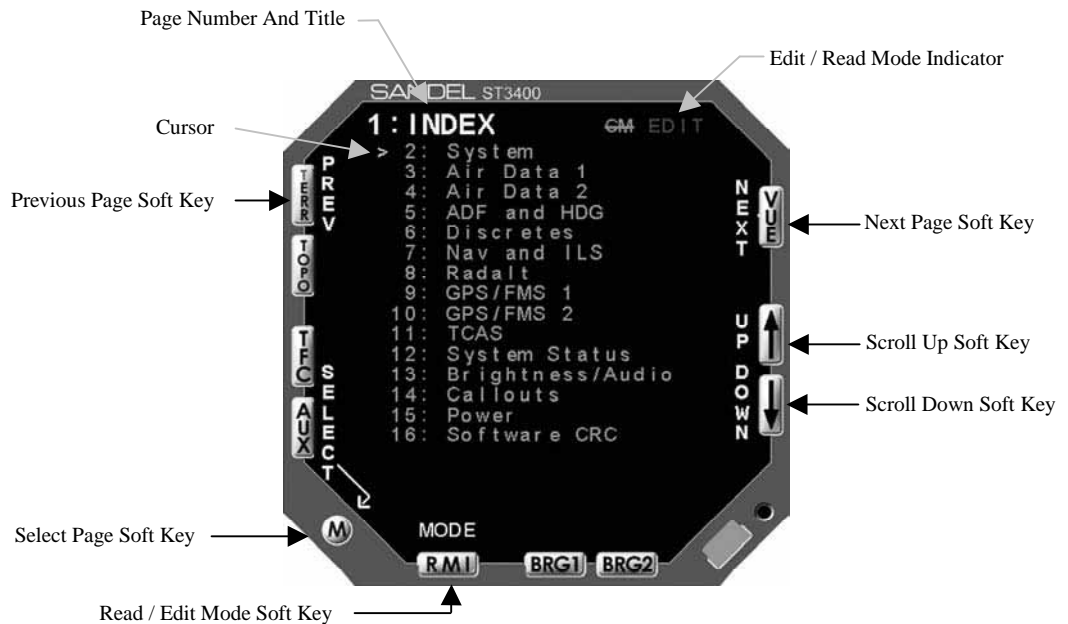

**Figure 6-1: Maintenance Index Page Display**

### 6.2.1 Maintenance Page Number/Title

The Maintenance Page Number/Title is displayed on every maintenance page showing the maintenance page number and title.

### 6.2.2 Cursor

The Cursor points to the item, which may be modified or selected. If there are no selectable items on the currently displayed maintenance page, the Current Line Indicator is not displayed.

The [UP] Soft key and [DOWN] Soft key are used to move the Cursor up and down through the list.

### 6.2.3 Soft Keys

The Soft Keys (see Table 6-1) are labeled to convey the context sensitive function of each button as required.

**Table 6-1: Common Maintenance Page Soft Keys**

MAINTENANCE PAGE SOFT KEYS		
DISPLAY INTERFACE	Name	Description
Previous Page	PREV	Returns to the prior maintenance page; if the first maintenance page is being displayed, moves to the last maintenance page.  The Maintenance Page Number/Title indicates the current maintenance page.
Next Page	NEXT	Advances to the next maintenance page; if the last maintenance page is being displayed, then moves to the first maintenance page.  The Maintenance Page Number/Title indicates the current maintenance page.
Select Page	SELECT	From the index page, jump directly to the indicated page.
Operation	OPER	From a maintenance page, if pressed once, will jump to Maintenance Index page. If pressed and held in, will transition into the Flight Operations displays.
Maintenance	MAINT	From a flight operations page, return to the Maintenance Index page. The Cursor will point to the maintenance page listing that was displayed prior to transitioning to the Flight Operations Test displays.
Scroll Up	UP	Moves the Cursor to the previous selectable item.  Hold key down to automatically repeat.  If there are no selectable items, key is disabled.
Scroll Down	DOWN	Scrolls the Current Line Indicator to the next selectable item.  Hold key down to automatically repeat.  If there are no selectable items, key is disabled.
Value/Model-Type Toggle	VALUE	Provides access to read secondary data from a piece of equipment.. The [DOWN]/[UP] soft keys will scroll through each Data Value that is available. If no secondary data is present, the Soft key is not displayed.
Type Toggle	TYPE	Returns function of [DOWN]/[UP] soft keys back from value selection monitoring into Type selection.
Model Toggle	MODEL	Returns function of [DOWN]/[UP] soft keys back from value selection monitoring into Model selection.
Read/Edit Enable	MODE	Change the edit/read mode for all maintenance pages. Only displayed from the <u>maintenance index</u> page. Press to toggle the write-protection of the configuration data.
Decrement	(-)	If the maintenance item is a numeric value, this key will decrease the value; if a multiple-choice entry then will move to the previous choice.

MAINTENANCE PAGE SOFT KEYS		
DISPLAY INTERFACE	Name	Description
		Hold to repeat.
Increment	(+)	If the maintenance item is a numeric value, this key increases the value; if the maintenance item is a multiple-choice entry then it is used to move to the next choice. Hold to repeat.

### 6.2.4 Edit/Read Mode Indicator

The Edit/Read Mode shows the state of the configuration write protection.

### 6.2.5 How to Access Maintenance Pages

The Maintenance Index shows all maintenance pages and allows the operator to jump directly to any other maintenance page by the use of Soft keys.

#### 6.2.5.1 Access the Maintenance Index page

Prior to applying power to the system:

Press and hold the [BRG 1] [BRG 2] selection buttons until the Maintenance Index page is displayed.

#### 6.2.5.2 Jump to a specific page

Press the [UP] Soft key or the [DOWN] softkey to move the Cursor.

Press the [SELECT] Soft key to jump to this page.

#### 6.2.5.3 Step Through Pages

Press the [PREV] or [NEXT] soft key.

## 6.3 Maintenance Pages

The sections that follow illustrate maintenance pages and describe each maintenance page and its contents. Maintenance pages may have names, indicators, readouts, lists, entries, and/or requests. A name is a text string that identifies a page or item. A Readout consists of value(s) and/or text string(s) that provide the status of an item. A multiple-choice list consists of a set of selectable items/choices where the set is shown with each item/choice on a separate line. A multiple-choice entry is an item with a set of selectable choices where the set is shown one choice at a time on a single line. A request is used to test a system function or to reset internal values.

### 6.3.1 System Maintenance Page

The System page (see Figure 6-2) provides information that identifies this unit and this unit's hardware/software.

The modifiable values (Aircraft Type through FLTA Alert Type) show the overall configuration for the unit and allow the operator to change these items.

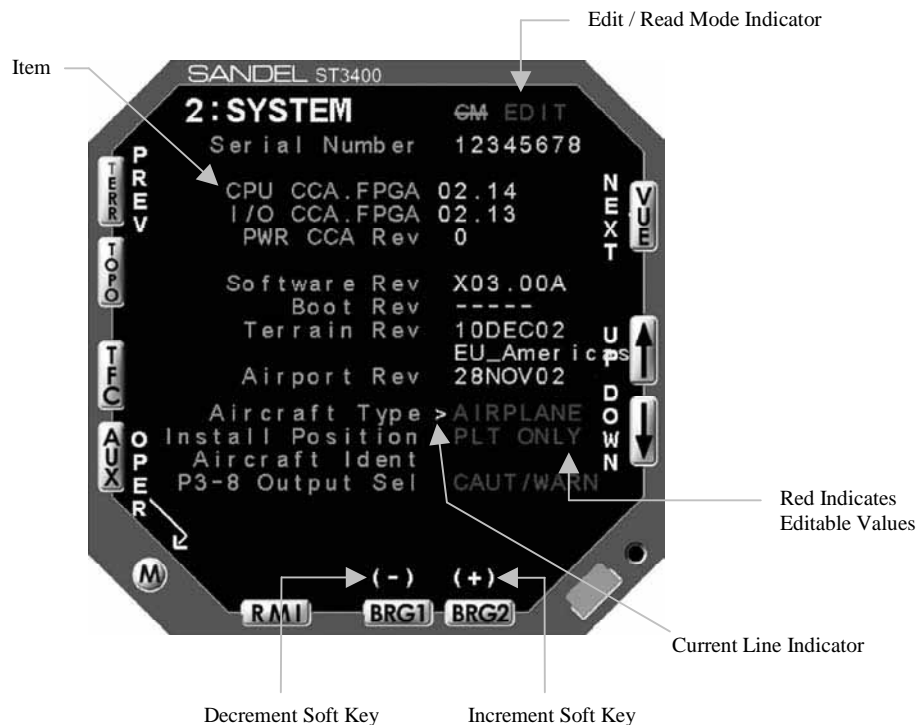

Figure 6-2: System (Edit Mode)

#### 6.3.1.1 Item

An Item identifies each maintenance item.

### 6.3.1.2 Editable Value

An Editable Value is an item whose value may be changed directly by the operator when the maintenance pages are in the edit mode. They are shown in RED. The Cursor points to the maintenance item to be modified. The [+]/[-] Soft Keys are used to change the value or scroll through the possible choices.

When the maintenance pages are in the read mode the operator can see but cannot change the items.

### 6.3.1.3 Internal Value

Internal Values are items shown for reference which cannot be edited. They are shown in GRN or YEL.

## 6.3.2 Air Data Page

The Air Data page (see Figure 6-3) contains the setup information for the #1 and #2 airdata systems. Use the [UP] or [DOWN] Softkeys to select a setup item. This will move the Cursor to the appropriate line and display the current input data value, input voltage (if applicable) and pin-pairs of the selected signal.

CBA: Corrected Baro Altitude Input  
BR: Baro Rate input (Vertical Speed)  
TA: True Airspeed



Figure 6-3: Air Data

### 6.3.3 ADF & HDG Page

The ADF & HDG page (see Figure 6-4) contains the setup information for the #1 and #2 ADF receivers (for RMI use) and #1 and #2 HDG systems. Use the [UP] or [DOWN] Softkeys to select a setup item. This will move the Cursor to the appropriate line and display the current input data value, input voltage (if applicable) and pin-pairs of the selected signal.

ADF: ADF receiver

HDG: HDG system

When selecting analog inputs, a VALID select will be present. If no valid signal is available for the interconnected equipment, set this to NONE which will treat the signal inputs as always valid. If a VALID signal is available, set appropriately to VALID HIGH or VALID LOW. The effect of these settings will be immediately shown at a VALID or INVALID data value at the top of the screen



Figure 6-4: ADF & HDG

### 6.3.4 Discretes Maintenance Page

The Discretes page (see Figure 6-5) shows all the discrete inputs.

A Discrete may be VALID-LOW or VALID-HIGH. In either case a 30K resistor is connected to pull the signal to the *invalid state* (ground or aircraft power) as applicable unless the valid signal is applied.



Figure 6-5: DISCRETES

### 6.3.5 NAV and ILS Page

The NAV and ILS page (see Figure 6-6) selects the configuration of NAV receiver and Glideslope receiver inputs. When the NAV input is selected to 429, the glideslope uses the same 429 port as the NAV. When analog, these two signals are selected separately.

The 429 data stream for NAV BRG can be selected TO VOR or FROM VOR. Set as appropriate for the receiver in use.

Once a selection is made, the port configuration for NAV will be automatically made based on the selection chosen and data will appear in the data VALUE area.

The data VALUE shows only a single data item. This page has an additional softkey labeled [VALUE] which can be used to scroll through all of the NAV and ILS data coming from the receiver. Use the [UP]/[DOWN] Soft keys to scroll through the various data items. Press the [TYPE] Soft key to exit the "Value" scroll function.

When the NAV input is analog composite, both the VOR bearing and the LOC deviation are demodulated from the analog data. The LOC deviation is used to qualify the GS data in addition to the analog GS flag.

Back Course (from the HSI) discrete input may be VALID-LOW or VALID-HIGH. This is used to inhibit the Glideslope alert GPWS mode 5.



Figure 6-6: NAV and ILS

### 6.3.6 RADALT Maintenance Page

The RADALT page (see Figure 6-7) selects the configuration of radar altimeter inputs. If no radar altimeters are installed set configuration of RA1 and RA2 to NONE.

Radar altimeters are selected by equipment type, i.e. ALT55 for Collins ALT55 altimeter, etc.

Once the equipment is selected, the radar altitude can be read from the data VALUE line to check for correct operation.

For analog inputs, a corresponding VALID input is present. Ensure that this item is VALID during normal operation and INVALID during TEST of the RA or when the RA is powered off.

Note: For Analog radar altimeters, mis-setting the Radar altimeter selection may show a correct value below 500' and an incorrect value above 500'. Therefore, if any troubleshooting is required regarding Radar Altimeter operation it is suggested that a test flight be performed in VFR conditions and the Radar Altitude be monitored on the ST3400 maintenance page simultaneously with the Radar Altimeter indicator to check for correct operation.

The Decision Height (D HGT) discrete input may be VALID-LOW or VALID-HIGH. This will produce a 'MINIMUMS' audio callout.

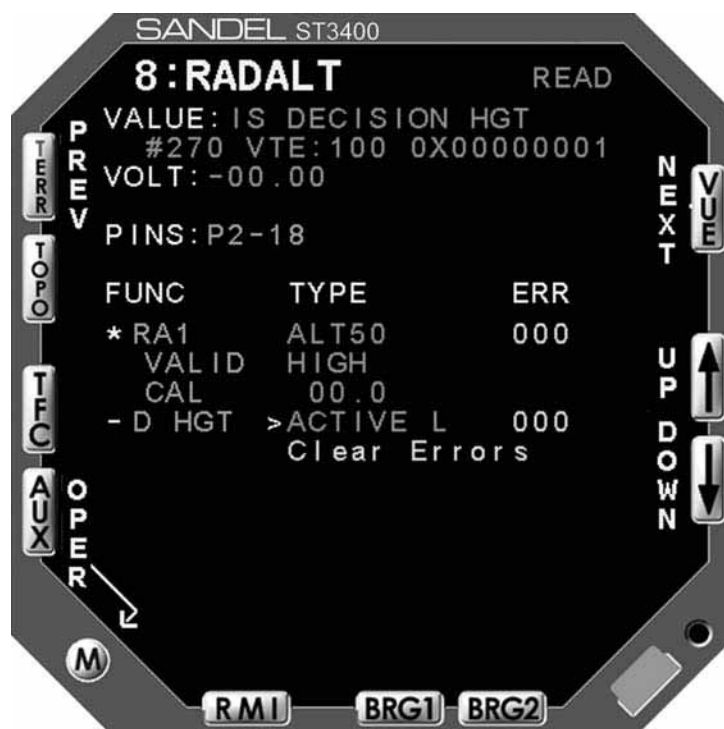

Figure 6-7: RADALT

### 6.3.7 GPS/FMS

There are two GPS/FMS pages (see Figure 6-8) for selection of Primary and Secondary receivers respectively.

The multiple-choice list allows the operator to specify the type of GPS/FMS connected to the primary GPS/FMS port. Select the desired receiver using the [UP]/[DOWN] Soft keys and use the [SET] softkey to make the selection.

Once a selection is made, the port configuration for FMS will be automatically made based on the selection chosen and data will appear in the data VALUE area.

The data VALUE shows only a single data item. This page has an additional softkey labeled VALUE which can be used to scroll through all of the GPS/FMS DATA coming from the receiver. Use the [UP]/[DOWN] Soft keys to scroll through the various data items. Press the [MODEL] Soft key to exit the "Value" scroll function.



Figure 6-8: GPS/FMS 1 Select Maintenance Page (typical)

#### 6.3.7.1 More Indicator

The More Indicator (see Figure 6-8) indicates more choices than the listings currently displayed on the screen. An arrow pointing down indicates that more choices exist below the last listing currently being displayed.

### 6.3.8 TCAS

The TCAS page (see Figure 6-9) shows selections available for Traffic.

The multiple-choice list allows the operator to specify the type of Traffic processor connected to the Traffic port. Select using the [UP]/[DOWN] Soft keys and use the [SET] softkey to make the selection.

Once a selection is made, the port configuration for Traffic will be automatically made based on the selection chosen and data will appear in the data VALUE area.

This page has an additional softkey labeled VALUE which can be used to scroll through all of the TCAS DATA coming from the processor. Use the [UP]/[DOWN] Soft keys to scroll through the various data items. Press the [MODEL] Soft key to exit the "Value" scroll function.

If a ST3400 in the field is being upgraded to display Traffic, please contact the factory for a software key necessary to enable the traffic display. The Traffic key can be entered on this screen manually. Software 3.00 and above is required to display traffic.



Figure 6-9: TCAS Select Maintenance Page (typical)

#### 6.3.8.1 More Indicator

The More Indicator (see Figure 6-9) indicates more choices than the listings currently displayed on the screen. An arrow pointing down indicates that more choices exist below the last listing currently being displayed.

### 6.3.9 Status Page

The Status page (see Figure 6-9) shows a composite status of all the ST3400 inputs.



Figure 6-9: STATUS

### 6.3.10 Callouts

The Callouts page (see Figure 6-10) allows enabling Radar Altitude auto callouts. Use the [UP] or [DOWN] Softkeys to select a setup item, this will move the Cursor to the appropriate line. [+] and [-] select “ON” or “OFF” for each callout.

Radar Altimeter input is required for the Callouts to function.



Figure 6-10: CALLOUTS

THIS PAGE INTENTIONALLY LEFT BLANK

# 7 POST INSTALLATION

## 7.1 General

Post Installation testing and diagnostic procedures are accessed and addressed through the Maintenance Interface.

### 7.1.1 Accessing Maintenance Pages

The Maintenance Interface allows the operator access to information pages.

The Maintenance Index page provides a menu that lists all accessible maintenance pages. The maintenance index menu lists the number and title for each maintenance page.

The Maintenance Interface can only be accessed during the system power-up sequence. Before applying power to the system, the operator must press and hold a combination of selection buttons. Exiting the maintenance pages completely must be done via a power down / power up sequence.

The interface with the operator is in the read mode upon initial entry into the maintenance pages. In the read mode all configuration values are read-only. To make changes, the edit/read mode must be changed to edit.

#### 7.1.1.1 Access the Maintenance Index page

Prior to applying power to the system:

Press and hold the [BRG 1] [BRG 2] selection buttons until the Maintenance Index page is displayed.

#### 7.1.1.2 Quickly access a specific page

Press the [UP] Soft key or the [DOWN] Soft key to move the Cursor.

Press the button labeled [SELECT] Soft key to display the page pointed to by the Cursor.

or

Press Indicator or press the [PREV] soft key or the [NEXT] soft key.

#### 7.1.1.3 Quickly return to the Maintenance Index page

Once any other maintenance page has been selected, for quick access to the Maintenance Index page:

Press the [OPER] Soft key if with in the Maintenance pages or, press and hold the [MAINT] Soft key if in the Flight Operation Display. Since these two soft keys are the same physical button, this quick access sequence is done by pressing the button twice.

## 7.2 Post Installation Testing

### 7.2.1 Power-On Self-Test

The Power-On Self-Test capability is an automatic test of equipment condition. It executes during the power-up sequence and reports any internal errors via on-screen readouts. The failure of the display itself is a major failure and will result in the inability to show further system-level error messages.

### 7.2.2 ST3400 TAWS/RMI

Verify DC Power, AC Power and Ground inputs to the Sandel ST3400 TAWS/RMI J1, J2 and J3 connectors before installing Sandel TAWS/RMI ST3400.

### 7.2.3 Install Sandel ST3400 TAWS/RMI into aircraft

Enter the maintenance mode by depressing “BRG1 & BRG2” and apply power to the unit.

### 7.2.4 Record the following Aircraft Configuration

Aircraft S/N: \_\_\_\_\_ Aircraft Registration: \_\_\_\_\_  
Aircraft Make: \_\_\_\_\_ Aircraft Model: \_\_\_\_\_

### 7.2.5 Record the following system information:

Date: \_\_\_\_\_  
ST3400 SN: \_\_\_\_\_  
ST3400 PN: \_\_\_\_\_  
ST3400 Software Rev: \_\_\_\_\_  
ST3400 Terrain Rev: \_\_\_\_\_  
ST3400 Map Data Rev: \_\_\_\_\_

### 7.2.6 Required Test Equipment:

1. Pitot Static Test Box
2. VOR/ILS Ramp Test Set
3. Digital Multimeter
4. Radar Altimeter Test Press to Test button, or Radar Altimeter Test Set

## 7.2.7 Brightness/Audio Page

The Brightness/Audio page (See Figure 7-1) shows along with other information the number of hours and cycles since the last lamp replacement.

It also allows the installer to specify the nominal and maximum audio levels for the low level audio output and trim the output level of the speaker audio output with respect to the low level output. The low level output acts as master gain..

The Reset Request allows the operator to reset the lamp hours and cycles when the lamp has been replaced. Resetting the lamp hours/cycles is initiated by selecting the “Reset” request and pressing the RESET soft key when in the Edit Mode. The Confirm Notice will be displayed. Press the RESET soft key again to confirm the action to reset the lamp hours and lamp cycles to zero or the CANCEL soft key to cancel the action with no changes made. If while waiting for confirmation the operator moves the Cursor, or exits the Brightness/Audio page, the action will be cancelled.

## 7.2.8 Alerts Test

Initiate an audio level test by selecting the desired volume level and pressing the TEST soft key (see Figure 7-1). This may be used to show the result of changing the audio level adjustments. The ‘Nominal’ and ‘Maximum levels are the master audio levels, which vary from Nominal to Maximum with airspeed. This adjustment should be made to adjust the headphone volume first (coming from pin P1-30). If the cockpit speaker output (P1-15) is used, adjust SPKR VOL to set the corresponding speaker volume. If the cockpit speaker is driven instead from the cockpit audio system, SPKR VOL is not used. During an alerts test, the external annunciators, if connected, will illuminate.

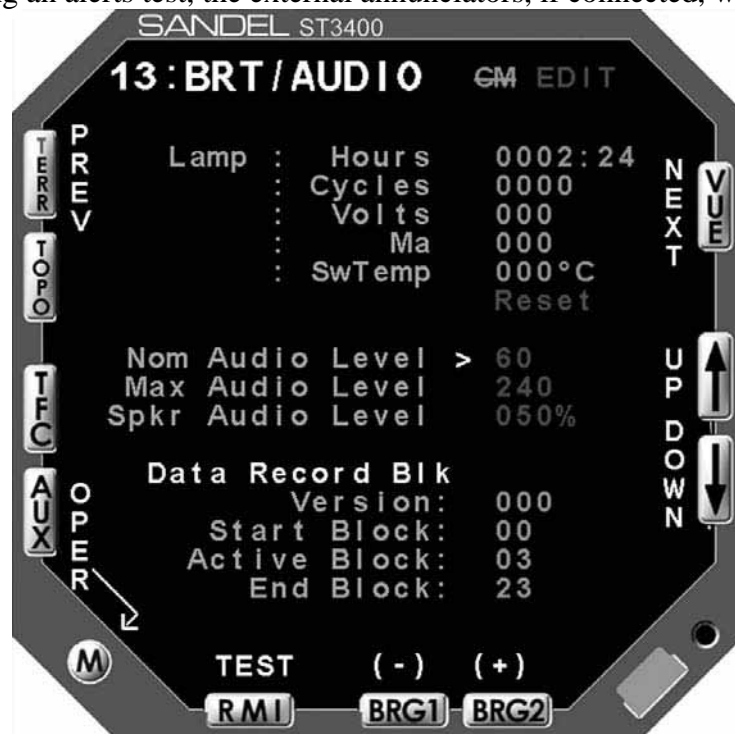

Figure 7-1: Brightness/Audio

## 7.2.9 Power Maintenance Page

The Diagnostics 1 page (see Figure 7-2) consists of readouts that monitor the unit's internal environment and the unit's power measurements for reference.

Any of these items that are outside normal operating limits will post an on-screen error by way of the systems built-in-test processes.



Figure 7-2: Internal Diagnostics 1

Note: On ST3400 with Mod-A, the following differences should be noted:

- The power supply monitor list is slightly different than shown above;
- Any power supply out-of-tolerance will change from green to red.
- If inverter inputs are floating they will read 1.3V not 0.0V. When grounded they will read 0.0 V

### 7.2.10 Software CRC Page

The Diagnostics 2 page (see Figure 7-3) consists of readouts that allow the operator to read CRC values of the data.

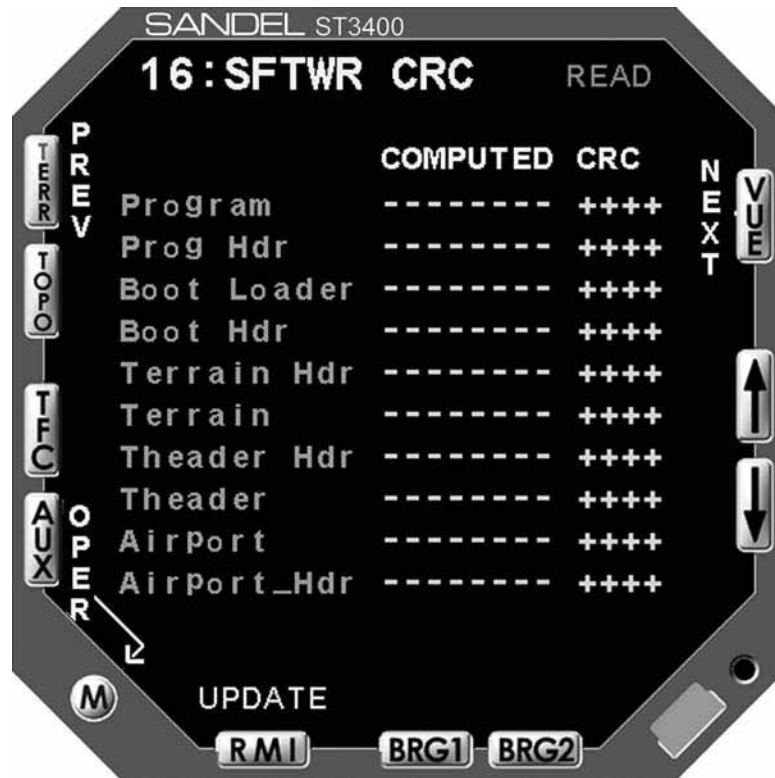

Figure 7-3: Internal Diagnostics 2

### 7.2.11 ST3400 CONFIGURATION

Configure and record configuration information from the ST3400 TAWS/RMI Maintenance and Summary pages

**Note:** Meet all approved maintenance and safety conditions.  
Use of appropriate ground power for the aircraft is required.

**Note:** Aircraft must be in the view of the GPS satellites for a valid GPS Position. FMS may show invalid (depending on model) until valid Groundspeed is achieved.

**RECORD ST3400 TAWS/RMI CONFIGURATION**

<b>PAGE</b>	<b>EQUIPMENT</b>	<b>FUNCTION</b>	<b>DATA TYPE</b>
	AIR DATA ADC-1		
3		CBA1	
3		BR1	
3		TA1	
3		OAT	
	AIR DATA ADC-2		
4		CBA1	
4		BR1	
4		TA1	
		OAT	
	ADF & HEADING		
5		ADF-1	
5		VALID	
5		ADF-2	
5		VALID	
5		HDG-1	
5		VALID	
5		HDG-2	
5		VALID	
	DISCERTES		
6		AP	
6		ALERT	
6		TEST	
6		FLAPS	
6		GEAR	
6		WHEELS	
6		WINDSHILD WIPERS	

<b>PAGE</b>	<b>EQUIPMENT</b>	<b>FUNCTION</b>	<b>DATA TYPE</b>
	NAV & ILS		
7		NAV-1	
7		CALIBRATE	
7		NAV-2	
7		CALIBRATE	
7		GS NO 1	
7		GS NO 2	
7		Back Course	
	RADIO ALTIMETER		
8		RA-1	
8		VALID	
8		Decision Height	
	GPS/FMS-1		
9		SELECTION	
	GPS/FMS-2		
10		SELECTION	
	TRAFFIC		
11		SELECTION	

## 7.2.12 AIR DATA INPUT TESTS

Follow Aircraft Manufacturers instructions and connect Pitot/Static test box to the aircraft Pitot/Static system. Select ST3400 to Maintenance Page 3&4: AIR DATA monitor the #1 and #2 Air data inputs.

Set the Pilot's altimeter to field elevation.

SIGNAL	FUNCTION	TOLERANCE	RECORD VALUE	PASS	FAIL
Field Elevation	CBA1	Verify altitude between Pilot's Altimeter and TAWS is within +/- 75 Feet			
Adjust Pitot/Static Test box to 1,000 ft over Field Elevation	CBA1	Verify altitude between Pilot's Altimeter and TAWS is within +/- 75 Feet			

Adjust the Pitot/Static Box for a climb and descent as required (Do not exceed aircraft VSI).

SIGNAL	FUNCTION	TOLERANCE	RECORD VALUE	PASS	FAIL
Adjust Pitot/Static Test box to 1,000, 2,000 and 4,000 fpm climb.	BR1	Verify vertical speed readings between Pilot's VSI and TAWS is within +/- 200 FPM			
Adjust Pitot/Static Test box to 1,000, 2,000 and 4,000 fpm descent.	BR1	Verify vertical speed readings between Pilot's VSI and TAWS is within +/- 200 FPM			

NOTE: If using Analog Baro Rate input this tolerance is increased +/- 400FPM

Adjust the Pitot/Static Box for field elevation.

SIGNAL	FUNCTION	TOLERANCE	RECORD VALUE	PASS	FAIL
Adjust Pitot/Static Test box to 120, 160 and 220 knots.	TA1	Verify airspeed readings between Pilot's airspeed and TAWS is within +/- 25 knots			
Field Temp	IAT OR OAT	Verify temperature within +/-5 degrees of ambient			

NOTE: Press "VALUE" softkey and then UP/DOWN softkeys to access IAT or OAT.

### 7.2.13 ADF INPUT TESTS

Select ST3400 to Maintenance Page 5: ADF & HDG.

SIGNAL	FUNCTION	RESULT	PASS	FAIL
Tune #1 ADF to station and select ADF Mode.	ADF1	Verify the #1 ADF bearing value matches bearing to the station within +/- 4 Degrees		
#1 ADF Valid	ADF1 VALID	Verify value of #1 ADF Valid indicates "VALID"		
Tune #1 ADF to station and select ANT Mode.	ADF1 VALID	Verify value of #1 ADF Valid indicates, "INVALID DATA"		
Tune #2 ADF to station and select ADF Mode.	ADF2	Verify the #2 ADF bearing value matches bearing to the station within +/- 4 Degrees		
#2 ADF Valid	ADF2 VALID	Verify value of #2 ADF Valid indicates "VALID"		
Tune #2 ADF to station and select ANT Mode.	ADF2 VALID	Verify value of #2 ADF Valid indicates, "INVALID DATA"		

### 7.2.14 HEADING INPUT TESTS

Select ST3400 to Maintenance Page 5: ADF & HDG

SIGNAL	FUNCTION	RESULT	PASS	FAIL
#1 Heading System use the free mode and slew the heading 360 degrees.	HDG1	Verify the #1 Mag Heading value matches the aircraft heading displayed on HSI within +/-4 Degrees		
#1 Heading Valid pull circuit breaker to go invalid	HDG1 VALID	Verify value of #1 Mag Heading Valid indicates, "INVALID DATA".		
#1 Heading Valid, reset circuit breaker.	HDG1 VALID	Verify value of #1 HDG Valid indicates, "VALID".		
#2 Heading System use the free mode and slew the heading 360 degrees.	HDG2	Verify the #2 Mag Heading value matches the aircraft heading displayed on HSI within +/-4 Degrees		
#2 Heading Valid pull circuit breaker to go invalid	HDG2 VALID	Verify value of #2 Mag Heading Valid indicates, "INVALID DATA".		
#2 Heading Valid, reset circuit breaker.	HDG2 VALID	Verify value of #2 HDG Valid indicates, "VALID".		

### 7.2.15 DISCRETE INPUTS TESTS

Check all discrete inputs that are interfaced to Sandel ST3400 TAWS/RMI.  
See Sandel ST3400 TAWS/RMI installation wiring diagrams for aircraft.

Select ST3400 to Maintenance Page 6: DISCRETES.

SIGNAL	FUNCTION	RESULT	PASS	FAIL
Engage Autopilot	AP ENGAGE	Verify value “ENGAGED” when AP engaged		
Disengage Autopilot	AP ENGAGE	Verify value “DISENGAGED” when AP disengaged		
Alert Inhibit	ALERT	Activate remote switch if installed, Verify value “ALERTS DISABLED”, release switch and verify value “ALERTS ENABLED		
Self Test	TEST	Activate remote switch if installed, Verify value “ALERTS TEST ENABLED” , release switch and verify value “ALERTS TEST DISABLED		
Cycle flaps through all settings	FLAPS	Verify value with flaps in landing configuration is “FLAPS DOWN” and in all other positions (including takeoff) is “FLAPS UP”.		
Landing Gear	GEAR	Verify value indicates “GEAR DOWN” on ground. Test Gear up <u>during flight test</u> .		
Windshield Wiper Input	WINDSHIELD WIPERS	Activate Windshield Wiper and verify input in Audio Output		

### 7.2.16 NAV& ILS INPUT TESTS

Select ST3400 to Maintenance Page 7: NAV & ILS.

SIGNAL	FUNCTION	RESULT	PASS	FAIL
#1 VOR/ILS Receiver, generate external VOR signal at 0 degrees TO.	NAV1	Nav 1 value VOR BEARING should read 0 degrees TO, calibrate BRG on page 6 if required. Verify value “ILS NOT TUNED” is shown.		
#1 VOR/ILS Receiver, generate external Localizer signal, vary the input deviation. Test at 0, +-.046 and +-.093DDM	NAV1	Nav 1 value should indicate “ILS TUNED” and “LOC DEV DDM” deviation should match generated signal.		

SIGNAL	FUNCTION	RESULT	PASS	FAIL
#1 VOR/ILS Receiver, generate external Glideslope signal, vary the input deviation. Test at 0, +-.046 and +-.093DDM	GS1	GS 1 value for “GS DEV DDM” deviation should match generated signal.		
#2 VOR/ILS Receiver, generate external VOR signal at 0 degrees TO.	NAV2	Nav 2 value VOR BEARING should read 0 degrees TO, calibrate BRG on page 6 if required. Verify value “ILS NOT TUNED” is shown.		
#2 VOR/ILS Receiver, generate external Localizer signal, vary the input deviation. Test at 0, +-.046 and +-.093DDM	NAV2	Nav 2 value should indicate “ILS TUNED” and “LOC DEV DDM” deviation should match generated signal.		
#2 VOR/ILS Receiver, generate external Glideslope signal, vary the input deviation. Test at 0, +-.046 and +-.093DDM	GS2	GS 2 value for “GS DEV DDM” deviation should match generated signal.		
Rotate HSI till Course Pointer is greater than +-90 degrees from Lubber Line	Back Course	Back Course will be enabled when Course Pointer is greater than +-90 degrees from Lubber Line		

### 7.2.17 RADAR ALTIMETER

**Note:** The Radar Altimeter test maybe performed by pressing the Radar Altimeter self test button, or by utilizing a Radar Altimeter test set. This manual references the use of the Radar Altimeter self test button and does not provide the information to setup and test the Radar Altimeter with a test set. For those applications utilizing relying on the use of a Radar Altimeter Test set, the operator should consult Radar Altimeters manufactures test setup and procedures for operation of the test set. The test that will be performed to validate the ST3400 TAWS/RMI operation with the Radar Altimeter will be tests defined below.

Select ST3400 to Maintenance Page 8: RAD ALT

SIGNAL	FUNCTION	RESULT	PASS	FAIL
#1 Radar Altimeter Receiver/Transmitter. Activate Rad Alt self Test	RA1	#1 Radar Altimeter Value should indicate within +-5 feet of Rad Alt test output.		
#1 Radar Altimeter Fail, pull circuit breaker to go invalid.	RA1 FAIL INPUT J2-13	Verify value of #1 Radar Altimeter Fail indicates, "J2-13 < +14VDC".		
#1 Radar Altimeter Fail reset circuit breaker.	RA1 FAIL INPUT J2-13	Verify value of #1 Radar Altimeter Fail indicates, "J2-13 > +14VDC".		
#1 Radar Altimeter Valid, pull circuit breaker to go invalid.	RA1 VALID	Verify value of #1 Radar Altimeter Valid indicates, "INVALID DATA".		
#1 Radar Altimeter Valid reset circuit breaker.	RA1 VALID	Verify value of #1 Radar Altimeter Valid indicates, "VALID".		
Rotate the DH Knob through Decision Height	Decision Height	Aural callout "MINIMUMS"		

### 7.2.18 GPS/FMS 1

Select ST3400 to Maintenance Page 9: GPS/FMS 1

SIGNAL	FUNCTION	RESULT	PASS	FAIL
#1 GPS receiver locked on with valid signal	#1 GPS POSITION	#1 GPS Lat and Long value displayed should match position on #1 GPS		
Turn off #1GPS receiver.	#1 GPS POSITION	#1 GPS position value Lat and Long will not be displayed.		

Check GPS Altitude if interfaced to ST3400

#1 GPS receiver locked on with valid signal	#1 GPS ALTITUDE	#1 GPS Altitude should match altitude displayed on GPS receiver.		
---	-----------------	--	--	--

**NOTE: Press "VALUE" softkey and then UP/DOWN softkeys to access to additional parameters and GPS Altitude.**

## 7.2.19 GPS/FMS 2

Select ST3400 to Maintenance Page 10: GPS/FMS 2

SIGNAL	FUNCTION	RESULT	PASS	FAIL
#2 GPS receiver locked on with valid signal	#2 GPS POSITION	#2 GPS Lat and Long value displayed should match position on #2 GPS		
Turn off #2GPS receiver.	#2 GPS POSITION	#2 GPS position value Lat and Long will not be displayed.		

Check GPS Altitude if interfaced to ST3400

#2 GPS receiver locked on with valid signal	#2 GPS ALTITUDE	#1 GPS Altitude should match altitude displayed on GPS receiver.		
---	-----------------	--	--	--

**NOTE: Press “VALUE” softkey and then UP/DOWN softkeys to access to additional parameters and GPS Altitude.**

## 7.2.20 TRAFFIC

Check traffic if interfaced to ST3400. Perform checkout per Traffic manufacturers installation manual.

Put Traffic device in self test mode	TRAFFIC	Traffic test pattern should display on the ST3400 traffic page.		
--------------------------------------	---------	---	--	--

## 7.2.21 Activate the TAWS Inhibit

Verify this inhibit annunciates on-screen TAWS inhibited when selected and does not annunciate on-screen TAWS inhibited when deselected.

Pass / Fail:

Remarks: \_\_\_\_\_

## 7.2.22 Power up the GPS/FMS

But do not initialize, do not accept/acknowledge Lat/Lon position, or enter and activate a flight plan. Verify the ST3400 flags the terrain display (GPS/FMS not active and GPS/FMS data output is not valid).

Pass / Fail:

Remarks: \_\_\_\_\_

### 7.2.23 Initialize GPS/FMS

And, activate a valid flight plan. Verify that the ST3400 displays valid terrain, and is function properly. Place a metallic object over the GPS/FMS antenna so as to block reception of all GPS/FMS satellites. Verify the GPS/FMS position solution is no longer valid, and that the flight plan is no longer active. Verify the ST3400 flags the terrain display. **Note: Some GPS/FMS receivers, only provide a valid output after developing a ground track.**

Pass / Fail:

Remarks: \_\_\_\_\_

### 7.2.24 Fail the GPS/FMS

And, verify that TERR FAIL is displayed, and the ST3400 displays “TAWS INH”.

Pass / Fail:

Remarks: \_\_\_\_\_

### 7.2.25 Run TAWS self-test

And, verify aural annunciations are acceptable in clarity and volume (both loudspeaker and headphone aural annunciations).

Pass / Fail:

Remarks: \_\_\_\_\_

### 7.2.26 Verify the ST3400 display

Verify display is viewable under all expected cockpit ambient light conditions (this test should be performed in bright daylight, and again at night or in a simulated dark cockpit).

Pass / Fail:

Remarks: \_\_\_\_\_

### 7.2.27 Verify the ST3400 manual display

Verify manual display brightness lighting control is operating, and provides display brightness over the full range of control for all normal cockpit lighting conditions.

Pass / Fail:

Remarks: \_\_\_\_\_

### **7.2.28 Verify the ST3400 visibility and accessibility**

Verify visibility and accessibility of the ST3400 display and controls from the pilot's seat. View the display from normal, expected viewing angles. This should include viewing the display from all viewing angles that might be encountered during normal cockpit operations.

Pass / Fail:

Remarks: \_\_\_\_\_

THIS PAGE INTENTIONALLY LEFT BLANK

## **8 INSTRUCTIONS FOR CONTINUED AIRWORTHINESS**

### **8.1 General**

Refer to Sandel Component Maintenance Manual for ST3400, SPN 82002-0133.

Normal maintenance activities performed on the ST3400 should follow standard industry maintenance practices. Maintenance practices, such as re-programming the Configuration Module and updating the Databases, are addressed in specific sections of this installation manual.

### **8.2 Databases**

System maintenance includes updating the Terrain and Airport databases.

Information regarding new releases and the content details of the databases may be obtained by visiting the Sandel website. Database updates may be ordered on-line. It is up to the ST3400 customer to determine if a specific database is applicable to their operations.

Terrain and Airport databases do not have to be updated at the same intervals.

### **8.3 Lamp Replacement**

The lamp in the ST3400 requires no scheduled maintenance.

### **8.4 Software Updates**

The Sandel will advise owners when new software is available. Software to be loaded at factory or authorized service center per Software Install Bulletin.

THIS PAGE INTENTIONALLY LEFT BLANK

## 9 INSTALLATION DRAWINGS

List of effective pages:

<b>Drawing</b>	<b>Rev</b>	<b>Title</b>
82002-05	A	LAYOUT, ST3400 INSTALLATION
82002-07	A	LAYOUT, ST3400
82002-10 pp 1	H	SYSTEM BLOCK DIAGRAM
82002-10 pp 2	G	MINIMUM REQ BLOCK DIAGRAM
82002-10 pp 3	J	POWER & AUDIO
82002-10 pp 4	J	GPS/FMS ARINC 429
82002-10 pp 5	H	RS232 GPS INTERFACE
82002-10 pp 6	G1	GARMIN GNS4XX/5XX
82002-10 pp 7	H	RAD ALT ANALOG
82002-10 pp 8	H	RAD ALT ARINC 429
82002-10 pp 9	F	HDG ARINC 429
82002-10 pp 10	G	HDG XYZ
82002-10 pp 11	B	ADF ARINC 429
82002-10 pp 12	G1	ADF XYZ
82002-10 pp 13	G1	ADF DC SIN/COS
82002-10 pp 14	H	NAV & LOC ANALOG
82002-10 pp 15	E	NAV & LOC ARINC 429
82002-10 pp 16	J	AIRDATA ANALOG
82002-10 pp 17	J1	AIRDATA ARINC 429/419
82002-10 pp 18	F	OAT
82002-10 pp 19	H	AIRFRAME
82002-10 pp 20	H2	ANNUNCIATORS
82002-10 pp 21	A1	INTERLINK
82002-10 pp 22	J	TRAFFIC

THIS PAGE INTENTIONALLY LEFT BLANK

## 10 APPENDIX A: EQUIPMENT AND INTERFACES

NOTE: CURRENT EQUIPMENT LIST IS BEING CONSTANTLY UPDATED. Please contact factory if equipment for your installation is not listed.

The following information may be added to and superseded by additional compatibility information in the future without invalidating the other information in this manual.

### 10.1 GPS/FMS

MFG	MODEL	INTERFACE TYPE	
FREEFLIGHT	1201	RS232	
GARMIN	GPS 165	429	
GARMIN	GNS4XX	429	*RS232
GARMIN	GNS5XX	429	*RS232
HONEYWELL	KLN90B-0200	429	
HONEYWELL	KLN900	429	
HONEYWELL	KLN94	RS232	
HONEYWELL	GNS-Xls	429 LOW SPEED	
HONEYWELL	GNS-Xls	429 HIGH SPEED	
II MORROW	2100	429	
II MORROW	2101	429	
TRIMBLE	2000/3000	RS422	
TRIMBLE	2101	RS422	
TRIMBLE	2101 I/O	429 LOW SPEED	
TRIMBLE	2101 I/O	429 HIGH SPEED	
UNIVERSAL	UNS-1X	429 LOW SPEED	

### 10.1.1 ARINC 429 LABELS for GPS/FMS

<b>LABEL</b>	<b>DATA</b>
074	Flight Plan
075	Waypoint Hdr
076	GPS Altitude
101	HDOP
102	VDOP
113	Waypoint Checksum
115	WYPT BEARING
136	VFOM
147	MagVar
150	Time HH:MM:SS
165	GPS Vertical Speed
167	ANP
247	HFOM
260	DATE
261	GPS Discrete
275	LRN Integrity
303	Waypoint Type
304	Waypoint ID LSB
305	Waypoint ID MSB
306	Waypoint Latitude
307	Waypoint Longitude
310	Present Position Latitude
311	Present Position Longitude
312	Ground Speed
313	Ground Track
315	Wind Speed
316	Wind Direction

## 10.2 RADAR ALTIMETER

<b>MANUFACTURER</b>	<b>MODEL</b>	<b>INTERFACE TYPE</b>
BENDIX/KING	KRA405	ANALOG
BENDIX/KING	KRA405B	ARINC 429
COLLINS	ALT50	ANALOG
COLLINS	ALT50A	ANALOG
COLLINS	ALT55	ANALOG
COLLINS	RAC870	ARINC 429
SPERRY	RT-220	ANALOG
SPERRY	RT-300	ANALOG

### 10.2.1 ARINC 429 LABELS for Radar Altimeter

LABEL	DATA
164	Radio Altitude

## 10.3 HEADING

MFG	MODEL	INTERFACE TYPE
BENDIX/KING	KCS 55A (KI525A)	XYZ
BENDIX/KING	KCS 305	XYZ
COLLINS	MCS 65 (DGS 55)	XYZ
SPERRY	C14A	XYZ

### 10.3.1 ARINC 429 LABELS for Heading

LABEL	DATA
320	Magnetic Heading

## 10.4 ADF

MANUFACTURER	MODEL	INTERFACE TYPE
BENDIX/KING	KR-87	SIN/COS
BENDIX/KING	KDF806	SIN/COS & XYZ
COLLINS	ADF-60A	SIN/COS & XYZ
COLLINS	ADF-60B	SIN/COS
COLLINS	ADF-462	ARINC 429

### 10.4.1 ARINC 429 LABELS for ADF

LABEL	DATA
162	ADF Heading

## 10.5 NAV

MANUFACTURER	MODEL	INTERFACE TYPE
BENDIX/KING	KN-40	ARINC 429
BENDIX/KING	KX165	ANALOG
BENDIX/KING	KNR634	ANALOG
COLLINS	VIR30/31/32	ANALOG
COLLINS	VIR432	ARINC 429
GARMIN	GNS430/530	ARINC 429

### 10.5.1 ARINC 429 LABELS for NAV

LABEL	DATA
173	LOCALIZER DEVIATION
174	GLIDESLOPE DEVIATION LABEL
222	VOR

## 10.6 AIRDATA

MFG	MODEL	INTERFACE TYPE
CIC	8800M, p/n 04077	ANALOG
COLLINS	ADC-80 F/H/N	Manchester Buss
COLLINS	ADC-80-G/J/K/L/M/Q/R	ARINC 575-3/ ARINC 419
COLLINS	ADC-82 ()	ARINC 575-3/ ARINC 419
COLLINS	ADC-85 ()	ARINC 575-3/ ARINC 419
HONEYWELL	AZ-241	ANALOG
HONEYWELL/ AMETEK	AM-250	ARINC 429
HONEYWELL	AZ-252	ARINC 429
HONEYWELL	AZ-600	ANALOG
HONEYWELL	AZ-648	ANALOG
HONEYWELL	AZ-810	ARINC 429
IS&S	ADDU	ARINC 429
PENNY & GILES	D60286	ANALOG
PENNY & GILES	90004-()	ARINC 429
SHADIN	ADC 2000	ARINC 429

### 10.6.1 ARINC 429 LABELS for Airdata

LABEL	DATA
203	Uncorrected Altitude
204	Corrected Baro Altitude
210	True Air Speed
211	Total Air Temperature
212	Baro Rate
213	Static Air Temperature

## 10.7 TRAFFIC

MFG	MODEL	INTERFACE TYPE
GoodricL- 3/GOODRICHh	TCAS 791/A	429
GoodrichL- 3/GOODRICH	Skywatch HPSKYWATCH HP	429
HONEYWELL	CAS 66	429
RyanRYAN	9900BX	429

# 11 APPENDIX B: ENVIRONMENTAL QUALIFICATION FORM

## RTCA/D0-160D Environmental Qualification Form

<b>NAMEPLATE NOMENCLATURE:</b> [(A2)(F1)]ZBAB[(H)(R)]XXXXXXZBABB[WW]M[XXF2]XXA	
<b>TYPE/MODEL NO:</b> ST3400	<b>TSO NUMBERS:</b> C151a, C92c, C113
<b>MANUFACTURER'S SPECIFICATION AND/OR OTHER APPLICABLE SPECIFICATION:</b>	
a.) Design Requirements & Objectives For ST3400 TAWS, document number 82002-0010	
b.) RTCA D0-160D Environmental Plan For Sandel ST3400 TAWS Class A/B, document number 82002-0090	
<b>MANUFACTURER:</b> Sandel Avionics, Inc.	
<b>ADDRESS:</b> 2401 Dogwood Way Vista, CA 92083	
<b>REVISION &amp; CHANGE NOS. OF D0-160:</b> Revision D, Change Nos. 1 & 2	<b>DATE TESTED:</b> From: 1/31/02 To: 3/20/02

ENVIRONMENTAL TESTS	RTCA/DO-160D SECTION	Equipment Test Category	Notes
Temperature & Altitude Temperature Variation (combined): Low Temperature -Ground Survival -Operational High Temperature -Ground Survival -Operational Altitude -Decompression -Overpressure	4.0 5.0 4.5.1  4.5.2 & 4.5.3  4.6 4.6.2 4.6.3	[(A2)(F1)B]	PASS
In-Flight Loss of Cooling	4.5.4	[(A2)Z]	PASS
Humidity	6.0	A	PASS
Operational Shock and Crash Safety	7.0	B	PASS
Vibration	8.0	[(H)(R)]	PASS: RESONANT FREQUENCIES: Section 8.7.2, Step a. and d.: Pre-Scan: X: 195Hz, Y: 500Hz, Z: 160Hz Post-Scan: X: 195Hz, Y: 450Hz, Z: 150Hz Section 8.8.1.3, Steps a. and e.: Pre-Scan: X: 190Hz, Y: 425Hz, Z: 145Hz Post-Scan: X: 190Hz, Y: 625Hz, Z: 145Hz Section 8.8.1.3, Steps b. and d.: Pre-Scan: X: 190Hz, Y: 390Hz, Z: 150Hz Post-Scan: X: 190Hz, Y: 625Hz, Z: 150Hz
Explosion	9.0	X	
Water-proofness	10.0	X	
Fluids Susceptibility	11.0	X	
Sand and Dust	12.0	X	
Fungus	13.0	X	
Salt Spray	14.0	X	
Magnetic Effect	15.0	Z	PASS
Power Input	16.0	B	PASS
Voltage Spike	17.0	A	PASS
Audio Frequency Susceptibility	18.0	B	PASS
Induced Signal Susceptibility	19.0	B	PASS
Radio Frequency Susceptibility	20.0	[WW]	PASS
Radio Frequency Emission	21.0	M	PASS
Lightning Induced Transient Susceptibility	22.0	[XX(EF)2]	PASS
Lightning Direct Effects	23.0	X	
Icing	24.0	X	
Electrostatic Discharge	25.0	A	PASS

THIS PAGE INTENTIONALLY LEFT BLANK

## **12 APPENDIX C: STC**

### **12.1 STC Permission**

Please contact Sandel Avionics, Inc. for permission to use these STC's.

## 12.2 STC: Cessna 421C Series

United States Of America  
Department of Transportation - Federal Aviation Administration  
**Supplemental Type Certificate**

*Number* SA01316LA

*This Certificate issued to*  
Sandel Avionics, Inc.  
2401 Dogwood Way  
Vista, California 92083

*certifies that the change in the type design for the following product with the limitations and conditions therefor as specified herein meets the airworthiness requirements of Part \*3 of the Civil Aviation Regulations.*  
(\*Certification basis is set forth in Type Certificate Data Sheet A7CE)

*Original Product Type Certificate Number:* A7CE  
*Make:* Cessna Aircraft Company  
*Model:* 421C Series

*Description of Type Design Change:* Installation of Sandel Avionics Terrain Awareness and Warning System in accordance with FAA Approved Sandel Avionics Master Drawing List, Document No. ST8690LA-A-01, Revision "B", dated June 4, 2002, or later FAA approved revision. FAA Approved Sandel Avionics Airplane Flight Manual Supplement, Document No. ST8690LA-A-10, Revision "Orig.", dated July 1, 2002, or later FAA approved revision.

*Limitations and Conditions:* This approval should not be incorporated in any aircraft unless it is determined that the interrelationship between this installation and any previous approved configuration will not introduce any adverse effect upon the airworthiness of the aircraft.

If the holder agrees to permit another person to use this certificate to alter the product, the holder must give the other person written evidence of that permission.

*This certificate and the supporting data which is the basis for approval shall remain in effect until surrendered, suspended, revoked or a termination date is otherwise established by the Administrator*

*Date of application:* February 13, 2001

*Date reissued:*

*Date of issuance:* July 10, 2002

*Date amended:*



*By direction of the Administrator*

*Albert Lam*  
(Signature)

for  
Manager, Systems & Equipment Branch, Los Angeles Aircraft Certification Office

(Title)

*Any alteration of this certificate is punishable by a fine of not exceeding \$1,000, or imprisonment not exceeding 3 years, or both.*

## 12.3 STC: King Air C90, 200, 300 and B300 Series

United States Of America  
Department of Transportation - Federal Aviation Administration

### Supplemental Type Certificate

*Number* SA01340LA

*This Certificate issued to* Sandel Avionics, Inc.  
2401 Dogwood Way  
Vista, California 92083

*certifies that the change in the type design for the following product with the limitations and conditions therefor as specified herein meets the airworthiness requirements of Part \*3 of the Civil Aviation Regulations and Part 23 of the Federal Aviation Regulation. (\*Certification basis is set forth in Type Certificate Data Sheet)*

*Original Product Type Certificate Number:* Please see attached FAA Approved Model List  
*Make:* Raytheon Aircraft Company  
*Model:* Please see attached FAA Approved Model List

*Description of Type Design Change:* Installation of Sandel Avionics Terrain Awareness and Warning System in accordance with FAA Approved Sandel Model List, Revision "Original", dated December 16, 2003, or later FAA approved revision.

*Limitations and Conditions:* This approval should not be incorporated in any aircraft unless it is determined that the interrelationship between this installation and any previous approved configuration will not introduce any adverse effect upon the airworthiness of the aircraft.

If the holder agrees to permit another person to use this certificate to alter the product, the holder must give the other person written evidence of that permission.

*This certificate and the supporting data which is the basis for approval shall remain in effect until surrendered, suspended, revoked or a termination date is otherwise established by the Administrator*

*Date of application:* September 14, 2001

*Date reissued:*

*Date of issuance:* July 19, 2002

*Date amended:* December 16, 2003

*By direction of the Administrator*



*Grant Sawyer*  
(Signature)

Project Manager, Systems & Equipment Branch,  
Los Angeles Aircraft Certification Office

(Title)

*Any alteration of this certificate is punishable by a fine of not exceeding \$1,000, or imprisonment not exceeding 3 years, or both.*

FAA Form 8110-2 (10-68)

Page 1 of 2

*This certificate may be transferred in accordance with FAR 21.47.*

# FAA Approved Model List (AML)

## Number SA01340LA

Sandel Avionics

For

Installation of a Sandel Terrain Awareness and Warning System (TAWS) ST3400

Issued Date: December 16, 2003  
 Amended Date: N/A  
 Revision: Original  
 Page 1 of 1

Item	Aircraft Make	Aircraft Model	Type Certificate Number	Certification Basis for Alteration	FAA Approved Master Drawing List		FAA Approved Airplane Manual Supplement		AML Approval Date
					Number	Revision/Date	Number	Revision/Date	
1	Raytheon Aircraft Company	C90	3A20	CAR 3 & FAR 23	ST9207LA-A-01	Rev "E" / 6-4-02	ST9207LA-A-10	"Orig." / 7-1-02	12-15-03
2	Raytheon Aircraft Company	200, 300, and B300	A24CE	FAR 23	ST9207LA-A-01	Rev. "F" / 11-17-03	ST9207LA-A-10	"Orig." / 7-1-02	12-15-03

FAA Approved:   
 Project Manager, Systems and Equipment Branch  
 Los Angeles Aircraft Certification Office

NOTES: UNLESS OTHERWISE SPECIFIED.

- LOCATE CLAMP TRAY WITH SUFFICIENT CLEARANCE ABOVE & BELOW
- POSITION THE SANDEL FLUSH MOUNTING SHIM (61062) BETWEEN THE BACK SIDE OF THE INSTRUMENT PANEL AND THE CLAMP TRAY NOTE THE LOCATION OF THE CHAMFER ON THE CORNER OF THE SHIM.
- STARTING AT THE BOTTOM SCREWS ATTACH THE CLAMP TRAY TO THE INSTRUMENT PANEL WITH 1 EA 8-32 X 2" AND 6-32 X .75" (BOTTOM) AND 1 EAS 8-32 X 2" AND 6-32 X .75" (TOP) PAN HEAD SCREWS.
- COMPLETE THE INSTALLATION PER INSTALLATION MANUAL SANDEL PART NUMBER 82002-IM (CURRENT REVISION).

REVISIONS				
ZONE	REV.	DESCRIPTION	DATE	APPROVED
	A	INITIAL RELEASE		

COMPUTER CONTROLLED DRAWING  
DO NOT REVISE MANUALLY

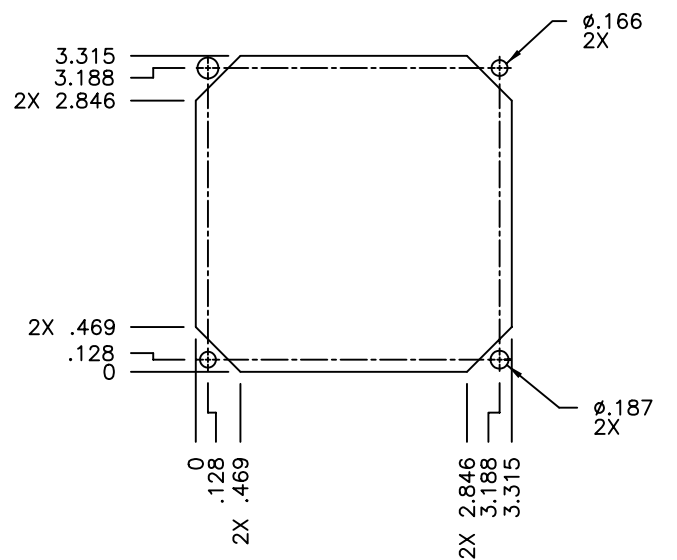
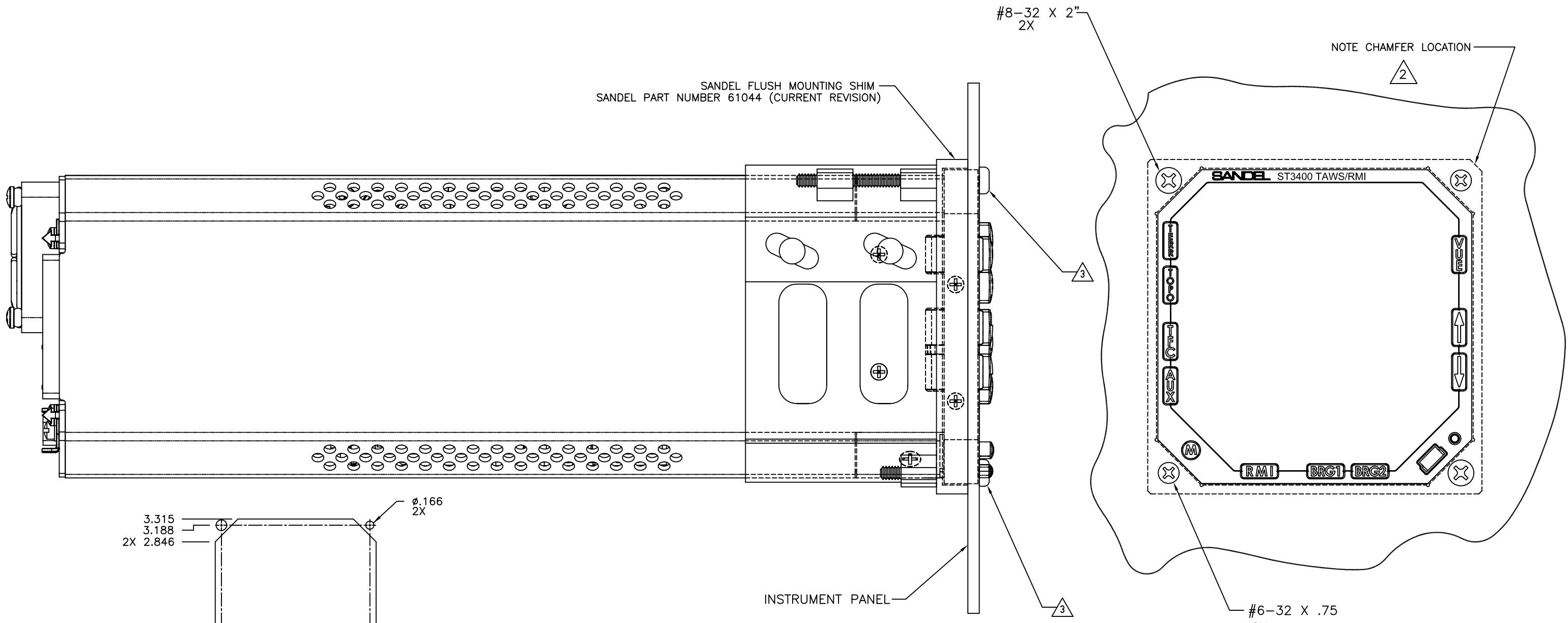

SUGGESTED PANEL CUT OUT (FLUSH MOUNT)

FLUSH MOUNT INSTALLATION

UNLESS OTHERWISE SPECIFIED DIMENSIONS ARE IN INCHES TOLERANCES ARE: FRACTIONS DECIMALS ANGLES $\pm 1/32$ .XX $\pm .01$ $\pm .5^\circ$ XXX $\pm .005$			ENGINEERING NO.		<b>SANDEL</b> VISTA, CA.	
MATERIAL SEE NOTES			APPROVALS M. KERSLAKE	DATE 4/11/02	LAYOUT, ST3400 INSTALLATION	
FINISH SEE NOTES			CHECKED	ISSUED	SIZE D	CATEGORY 05
TAB NO.	NEXT ASSY	USED ON	APPLICATION DO NOT SCALE DRAWING		DWG. NO. 82002	REV. A
					SCALE 2:1	SHEET 1 OF 2

NOTES: UNLESS OTHERWISE SPECIFIED.

1. LOCATE CLAMP TRAY WITH SUFFICIENT CLEARANCE ABOVE & BELOW
2. STARTING AT THE BOTTOM SCREWS ATTACH THE CLAMP TRAY TO THE INSTRUMENT PANEL WITH 1 EA 8-32 X 2" AND 6-32 X .75" (BOTTOM) AND 1 EA 8-32 X 2" AND 6-32 X .75" (TOP) PAN HEAD SCREWS.
3. COMPLETE THE INSTALLATION PER INSTALLATION MANUAL SANDEL PART NUMBER 82002-IM (CURRENT REVISION).

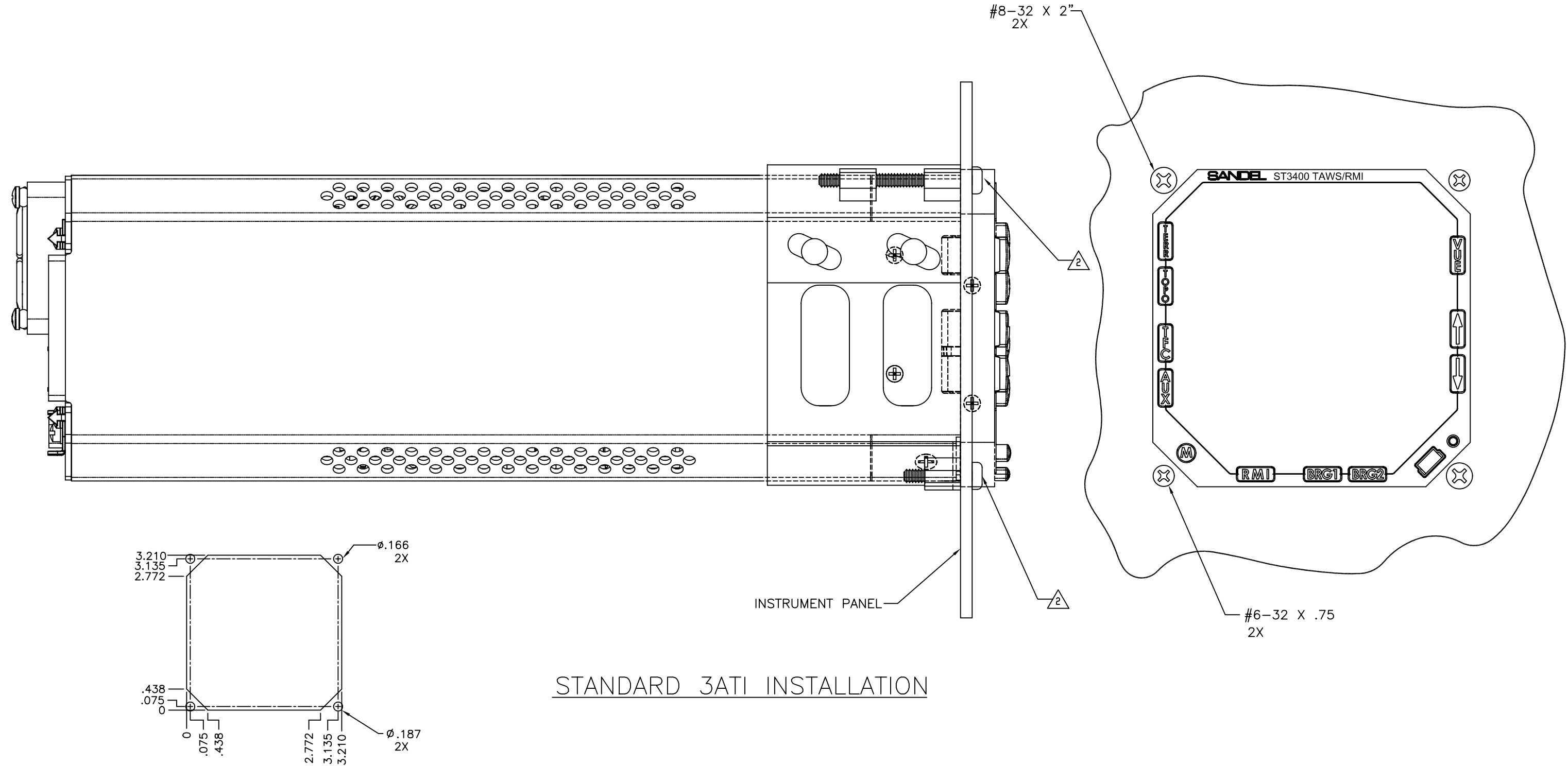

INSTRUMENT PANEL

STANDARD 3ATI INSTALLATION

SUGGESTED PANEL CUT OUT (STANDARD 3ATI)

SIZE	CATEGORY	DWG. NO.	REV.
D	05	82002	A
SCALE	2:1		SHEET 2 OF 2

NOTES: UNLESS OTHERWISE SPECIFIED

REVISIONS			
REV.	DESCRIPTION	DATE	APPROVED
A	INITIAL RELEASE		

COMPUTER GENERATED DRAWING  
DO NOT REVISE MANUALLY

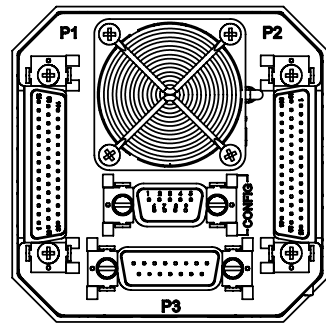

BACK VIEW

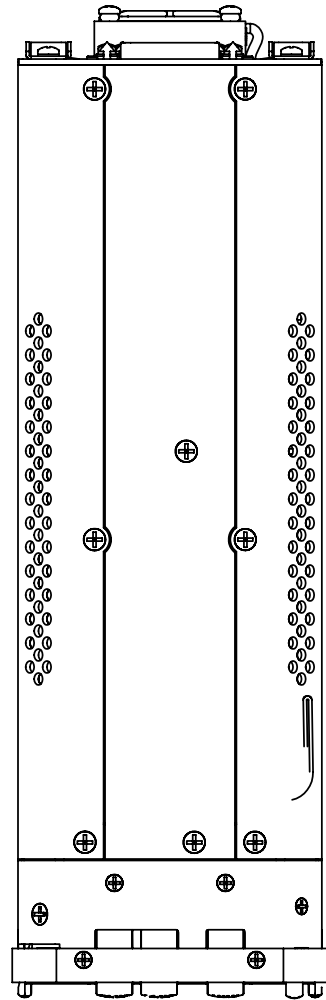

BOTTOM VIEW

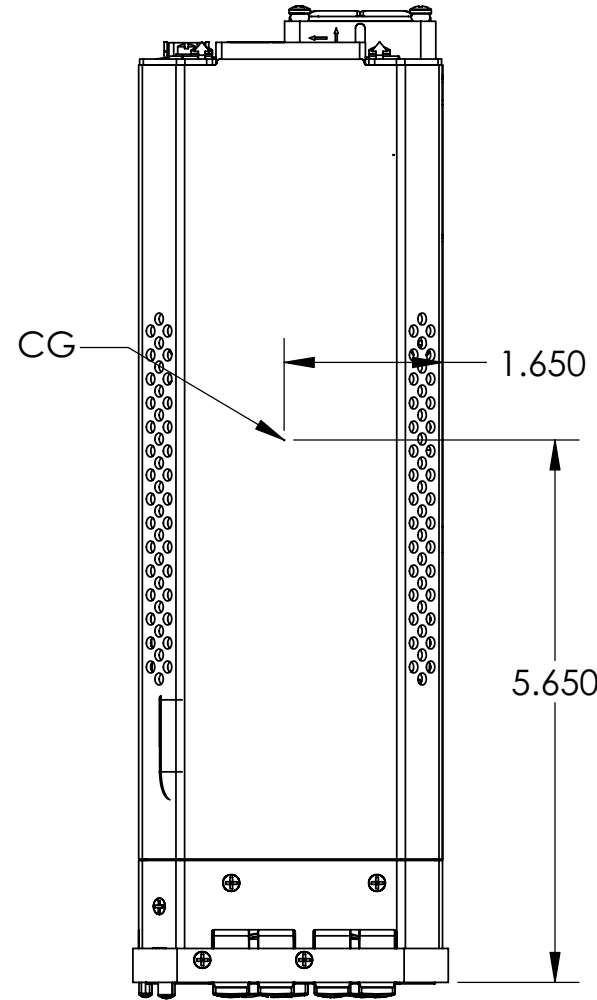

LEFT SIDE VIEW

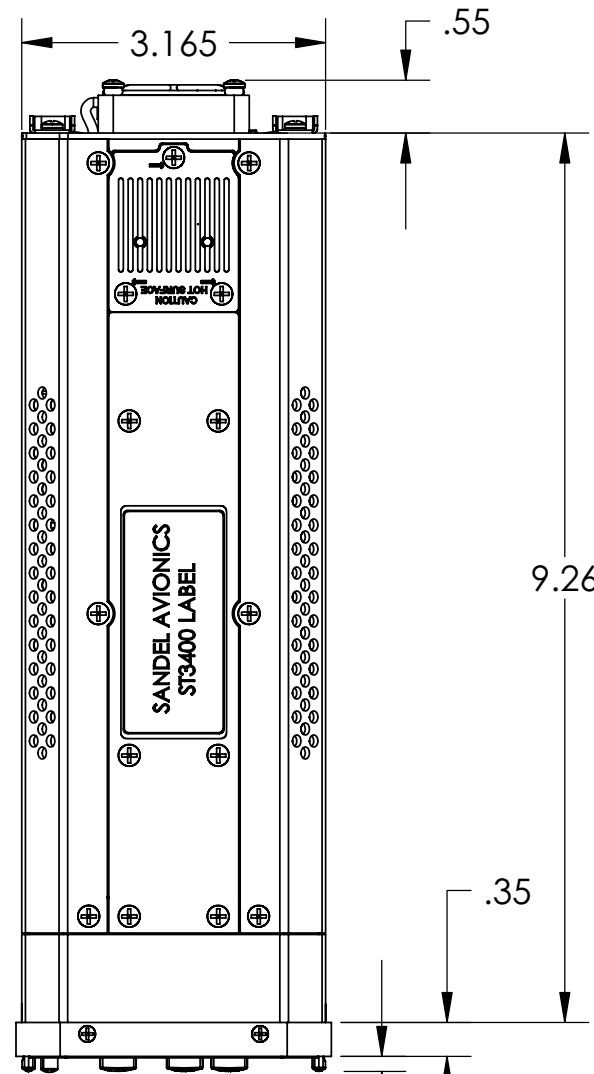

TOP VIEW

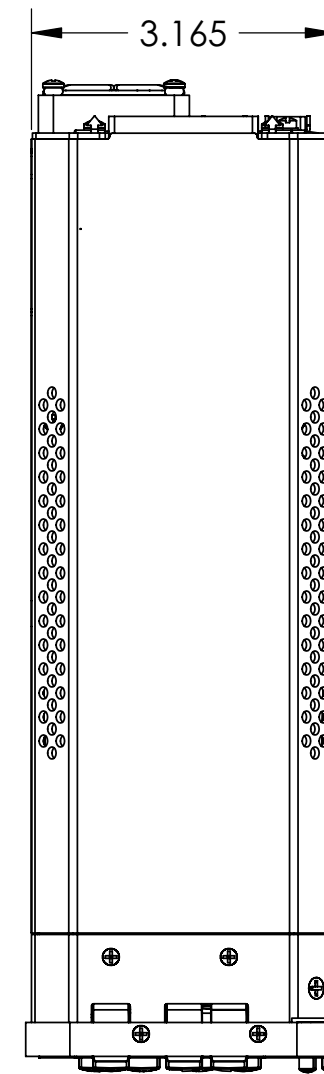

RIGHT SIDE VIEW

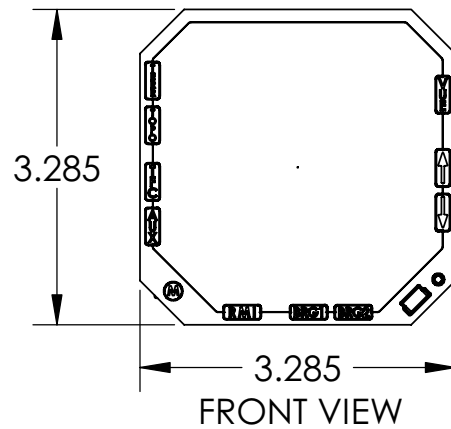

FRONT VIEW

ITEM NO.	PART OR IDENTIFYING NO.	NOMENCLATURE OR DESCRIPTION	MATERIAL SPECIFICATION	QTY REQD
PARTS LIST				
UNLESS OTHERWISE SPECIFIED DIMENSIONS ARE IN INCHES TOLERANCES ARE:		CAD GENERATED DRAWING, DO NOT MANUALLY UPDATE		
FRACTIONS DECIMALS ANGLES		APPROVALS DATE		
±X/X .XX ±.01 ±.5		DRAWN P.TAYLOR 01/24/02		
.XXX ±.005		CHECKED		
MATERIAL --		RESP ENG		
FINISH --		MFG ENG		
NEXT ASSY USED ON		APPROVAL		
APPLICATION		DO NOT SCALE DRAWING		

SANDEL VISTA, CA LAYOUT, ST3400		SIZE B	CATEGORY 07	DWG. NO. 82002	REV. A
		SCALE: 1:2	CAD FILE:	SHEET 1 OF 1	

DATE	REV	COMMENTS
04/11/02	A	A/R 484 INITIAL RELEASE
05/21/02	B	A/R 525 ADDED OAT TO AIRDATA
08/04/03	G	A/R 638 Configuration Module Optional
02/18/04	H	A/R 675 Added Traffic Interface.

COMPUTER CONTROLLED DRAWING  
DO NOT REVISE MANUALLY

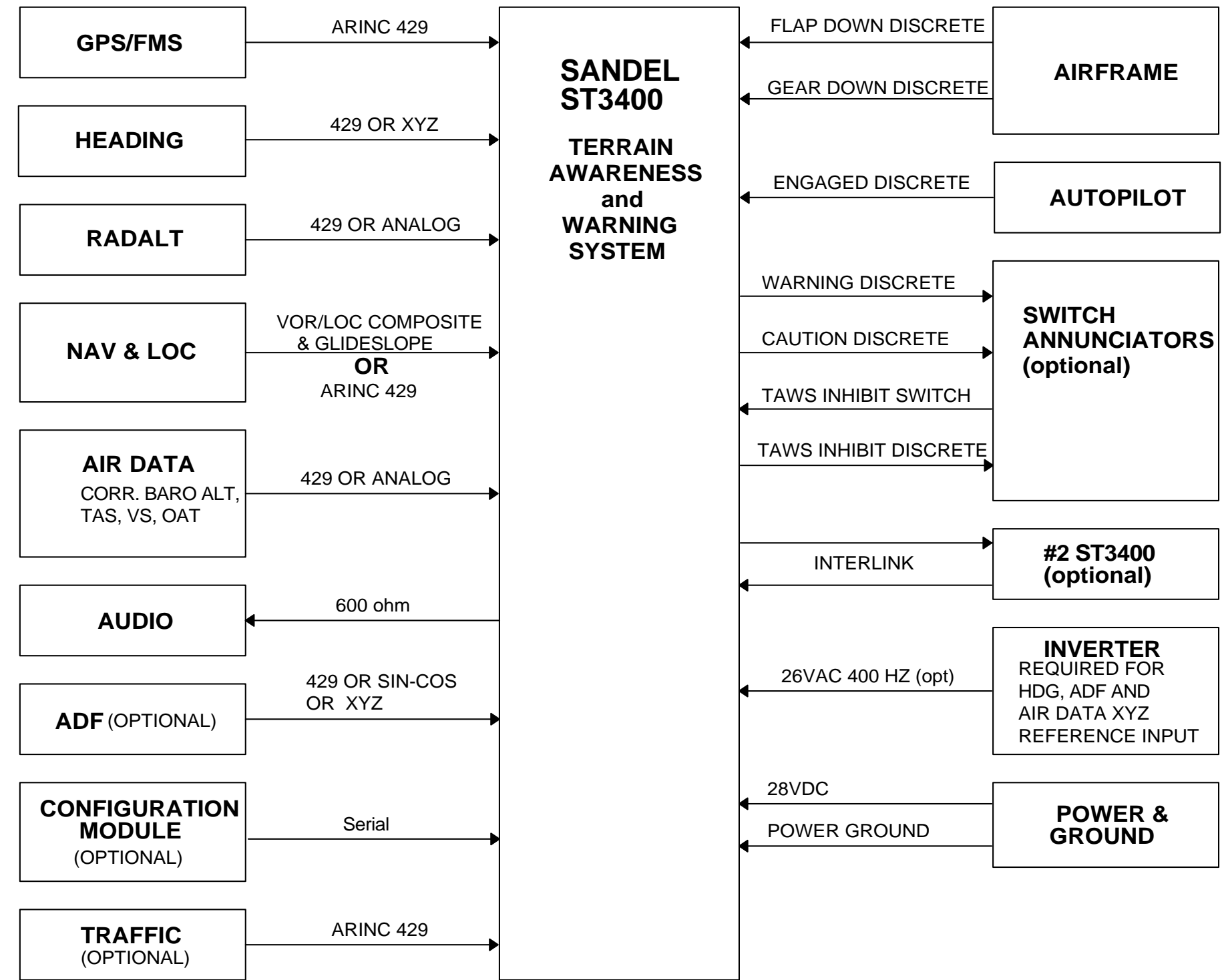

<b>SANDEL®</b>		Vista, Ca.
Category	ST3400 INSTALLATION DRAWING	
Title	SYSTEM BLOCK DIAGRAM	
Size B	Document Number	Rev
	<b>82002-10</b>	<b>H</b>
Create: Wednesday, August 15, 2001 Mod: Wednesday, April 07, 2004 Sheet 1		

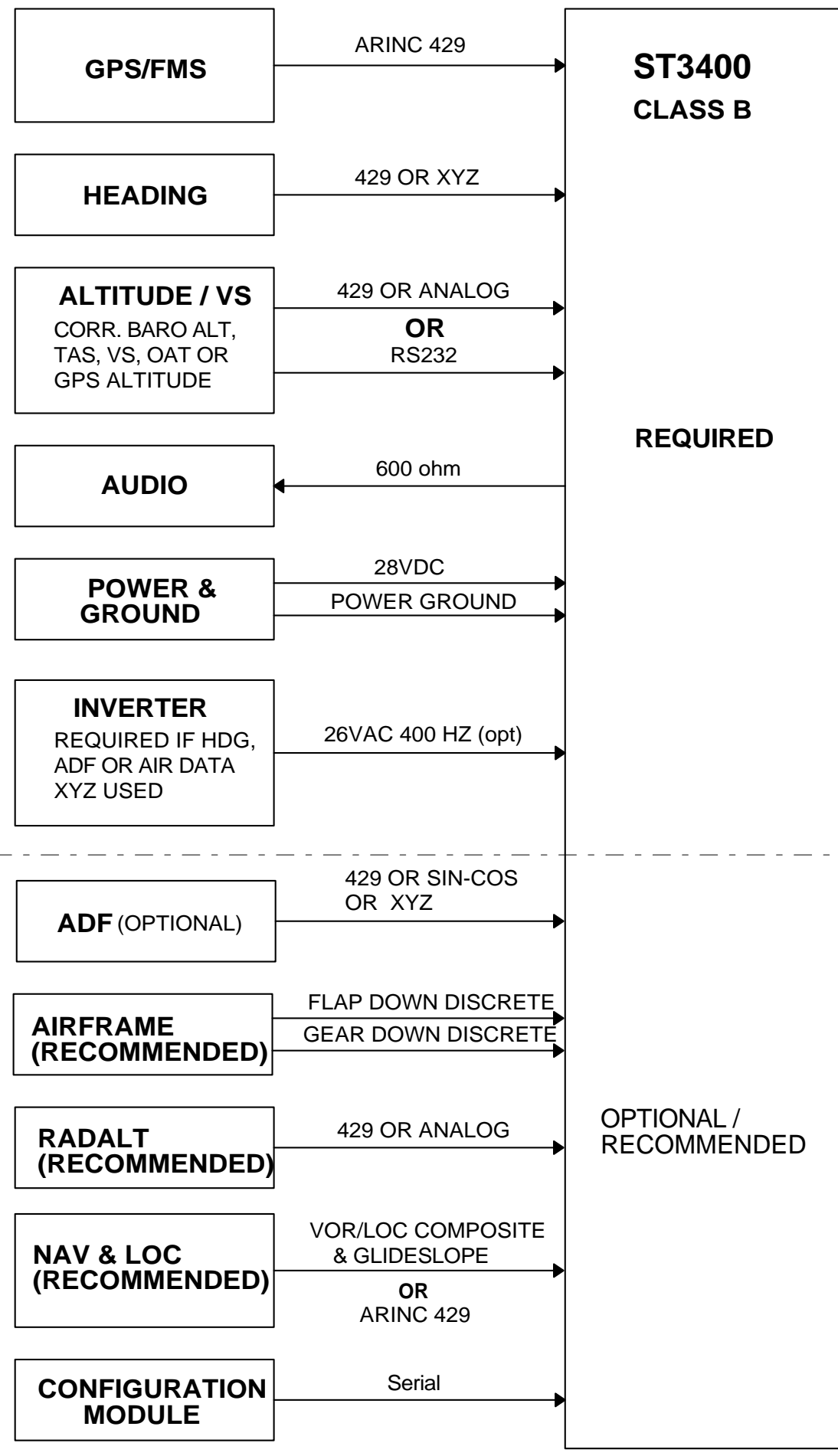
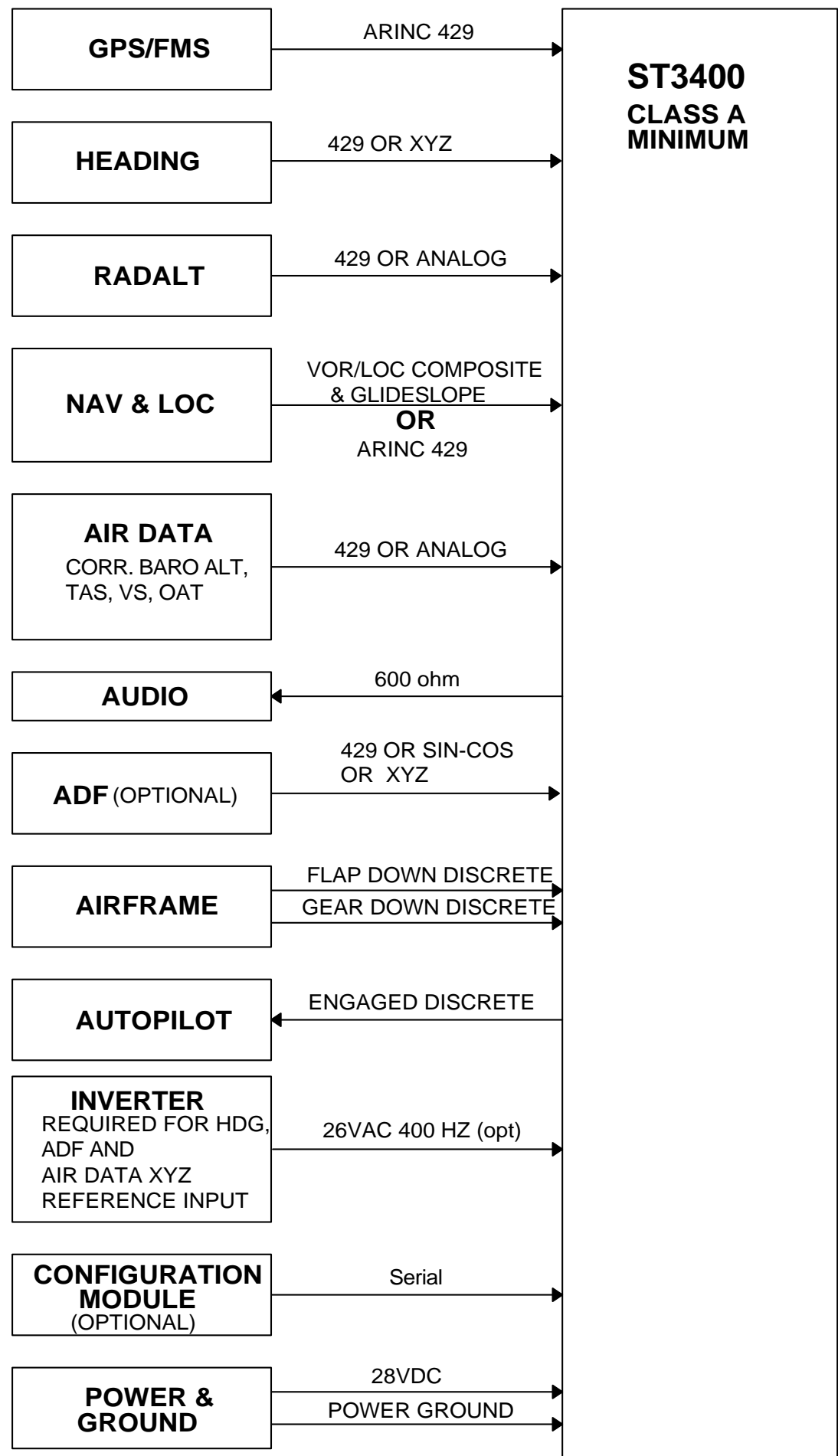

DATE	REV	COMMENTS
04/11/02	A	A/R 484 INITIAL RELEASE
05/21/02	B	A/R 525 ADDED OAT TO AIRDATA CLASS A ADDED AIRDATA TO CLASS B
02/21/03	C	A/R 610 ADDED GPS ALTITUDE TO CLASS B
04/15/03	F	A/R 626 IMPROVED CLASS-B CHART.
08/04/03	G	A/R 638 Configuration Module Optional

COMPUTER CONTROLLED DRAWING  
DO NOT REVISE MANUALLY

**SANDEL**® Vista, Ca.

Category: ST3400 INSTALLATION DRAWING

Title: **MINIMUM REQ BLOCK DIAGRAM**

Size B Document Number: **82002-10** Rev **G**

Create: Wednesday, August 15, 2001 Mod: Wednesday, April 07, 2004 Sheet 2

DATE	REV	COMMENTS
04/11/02	A	A/R 484 INITIAL RELEASE
04/12/03	F	A/R 626 ADDED NOTE 3
04/07/04	H2	A/R 697 ADDED AUDIO ENABLE RELAY
07/1/04	J	A/R 717 Speaker output available for MOD-A

COMPUTER CONTROLLED DRAWING  
DO NOT REVISE MANUALLY

### Primary Power

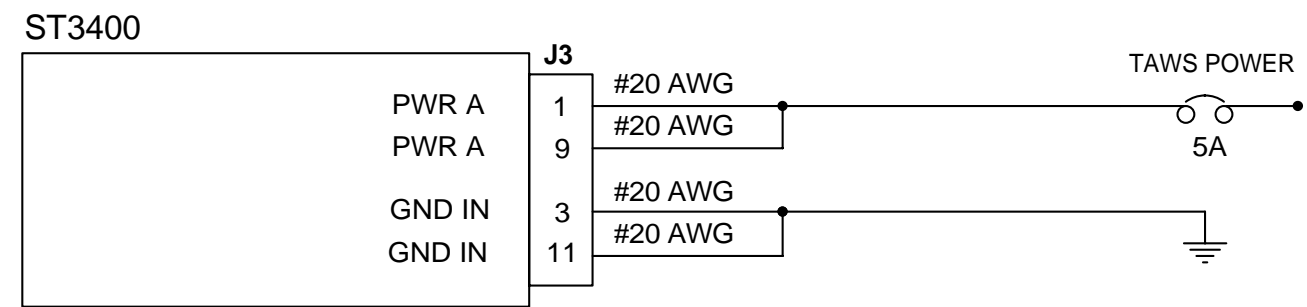

### Inverter

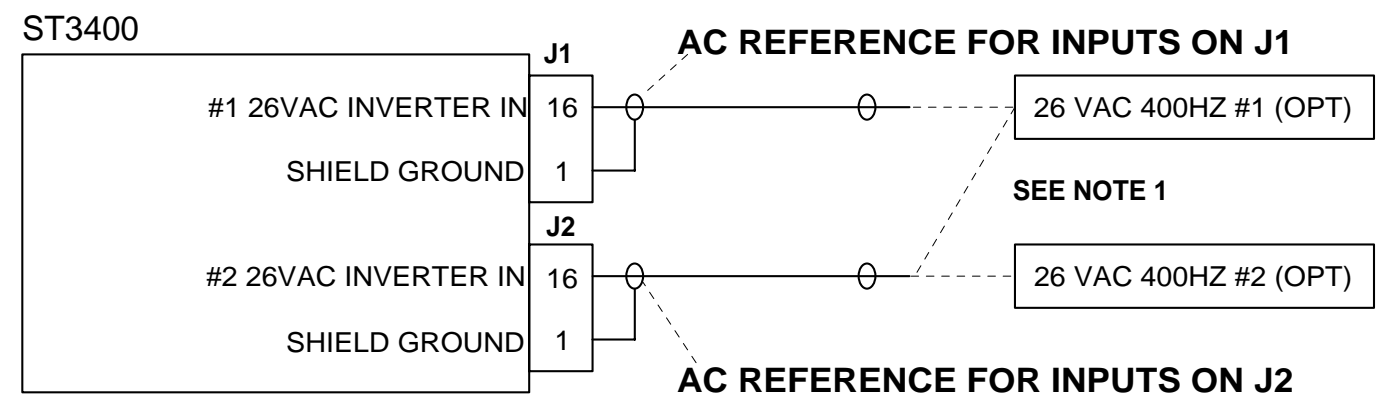

### Audio Output

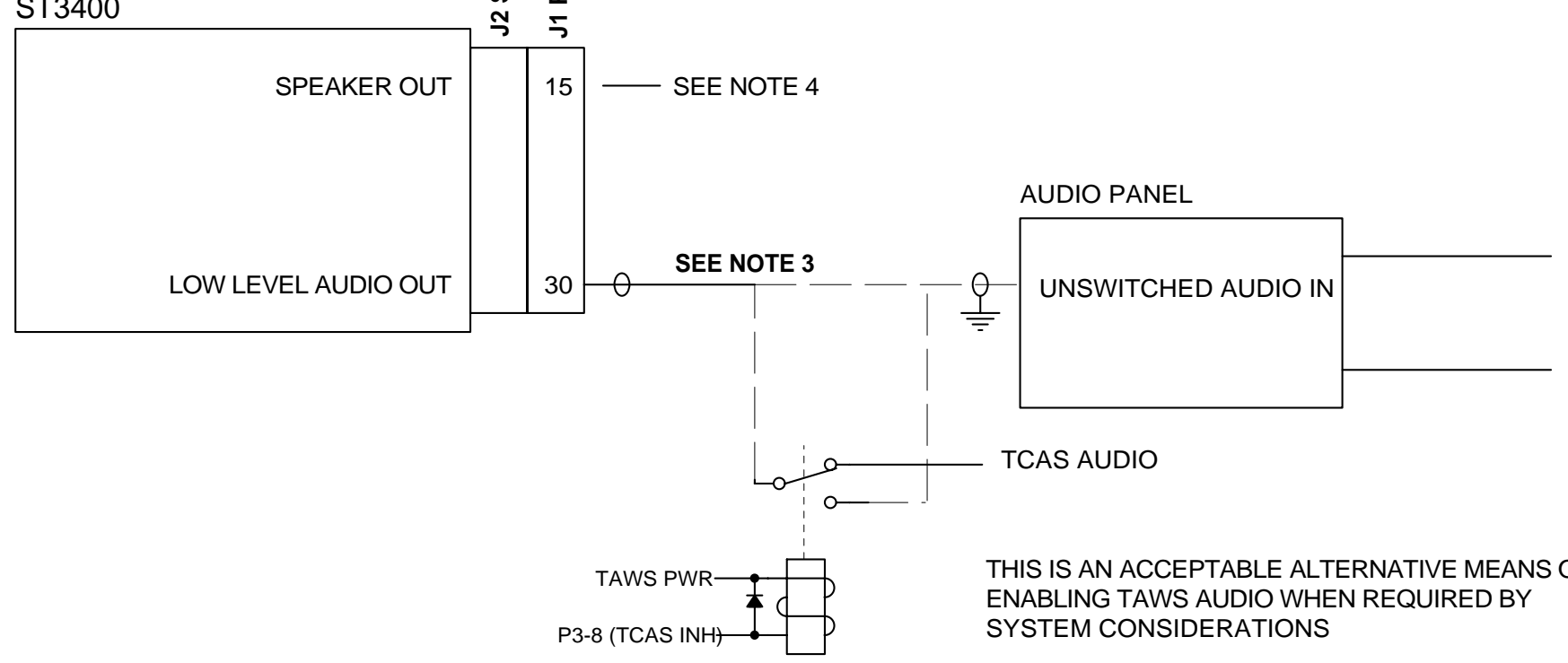

### NOTES:

1. AC REFERENCE REQUIRED FOR ARINC 407 XYZ INPUTS ARE USED ON J1 & J2. (HDG, ADF & AIRDATA XYZ)
2. #2 INVERTER INPUT CAN BE JUMPERED FROM #1 INVERTER INPUT OR A SEPERATE #2 INVERTER INPUT IF REQUIRED. ARINC 407 XYZ INPUTS ON J2 MUST HAVE THE SAME AC REFERENCE AS #2 INVERTER INPUT P2-16.
3. IF AIRCRAFT HAS ONLY ONE UNSWITCHED INPUT AND MULTIPLE SOURCES, ADD A 470-680 OHM RESISTOR IN SERIES WITH EACH SOURCE FOR ISOLATION OR USE RELAY
4. Speaker output available with MOD-A only. Drive separate cockpit speaker if existing audio amplifier not available. If there is a TCAS installed ensure prioritization is accomplished with a relay.

<b>SANDEL</b>		Vista, Ca.
Category	ST3400 INSTALLATION DRAWING	
Title	POWER & AUDIO	
Size B	Document Number	Rev
	<b>82002-10</b>	<b>J</b>
Create: Monday, July 02, 2001		Mod: Thursday, August 05, 2004 Sheet 3

DATE	REV	COMMENTS
04/11/02	A	A/R 484 INITIAL RELEASE
09/25/02	B	A/R 564 added Garmin GPS165
02/21/03	C	A/R 610 Depict J1 & J2 Separately Added II Morrow 2001, 2101 & UNS-1X
08/04/03	G	A/R 638 added Trimble 2101 I/O
10/17/03	G1	A/R 661 added King KLN 900
08/05/04	J	A/R 717 GPS/FMS ARINC PIN 17 WAS GNS GNS-X

COMPUTER CONTROLLED DRAWING  
DO NOT REVISE MANUALLY

### GPS/FMS 1

#### ST3400

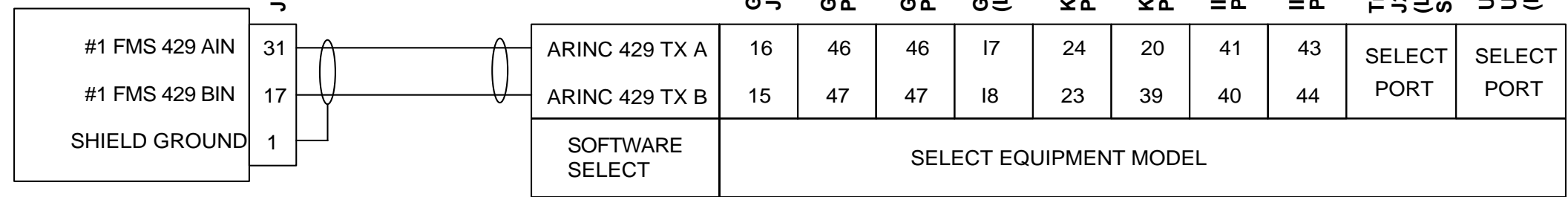

### GPS/FMS 2

#### ST3400

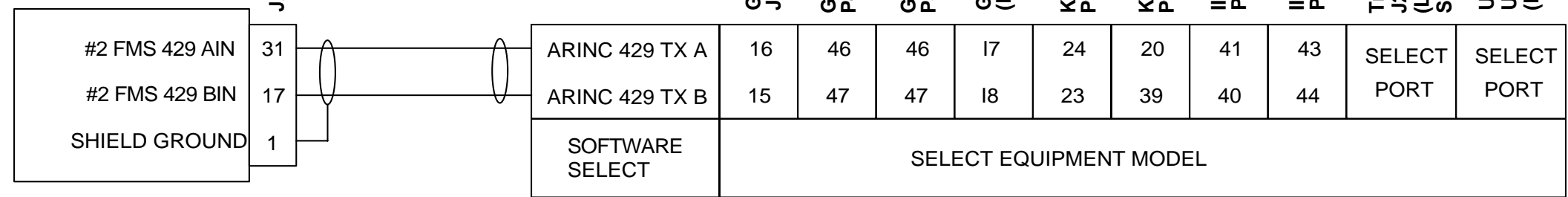

SECONDARY INPUTS OPTIONAL

<b>SANDEL</b>		Vista, Ca.
Category	ST3400 INSTALLATION DRAWING	
Title	GPS/FMS ARINC 429	
Size B	Document Number	Rev
	<b>82002-10</b>	<b>J</b>
Create: Monday, July 02, 2001		Mod: Tuesday, August 10, 2004   Sheet 4

DATE	REV	COMMENTS
02/21/03	E	A/R 610 INITIAL RELEASE
04/14/03	F	A/R 626 Added KLN94 GPS
10/17/03	G1	A/R 661 added Trimble 2000/3000/2101 and UPS GX Series
02/18/04	H	A/R 675 Added FreeFlight 1201 GPS #2 Shown. Pin 26 shown grounded

COMPUTER CONTROLLED DRAWING  
DO NOT REVISE MANUALLY

### GPS/FMS 1

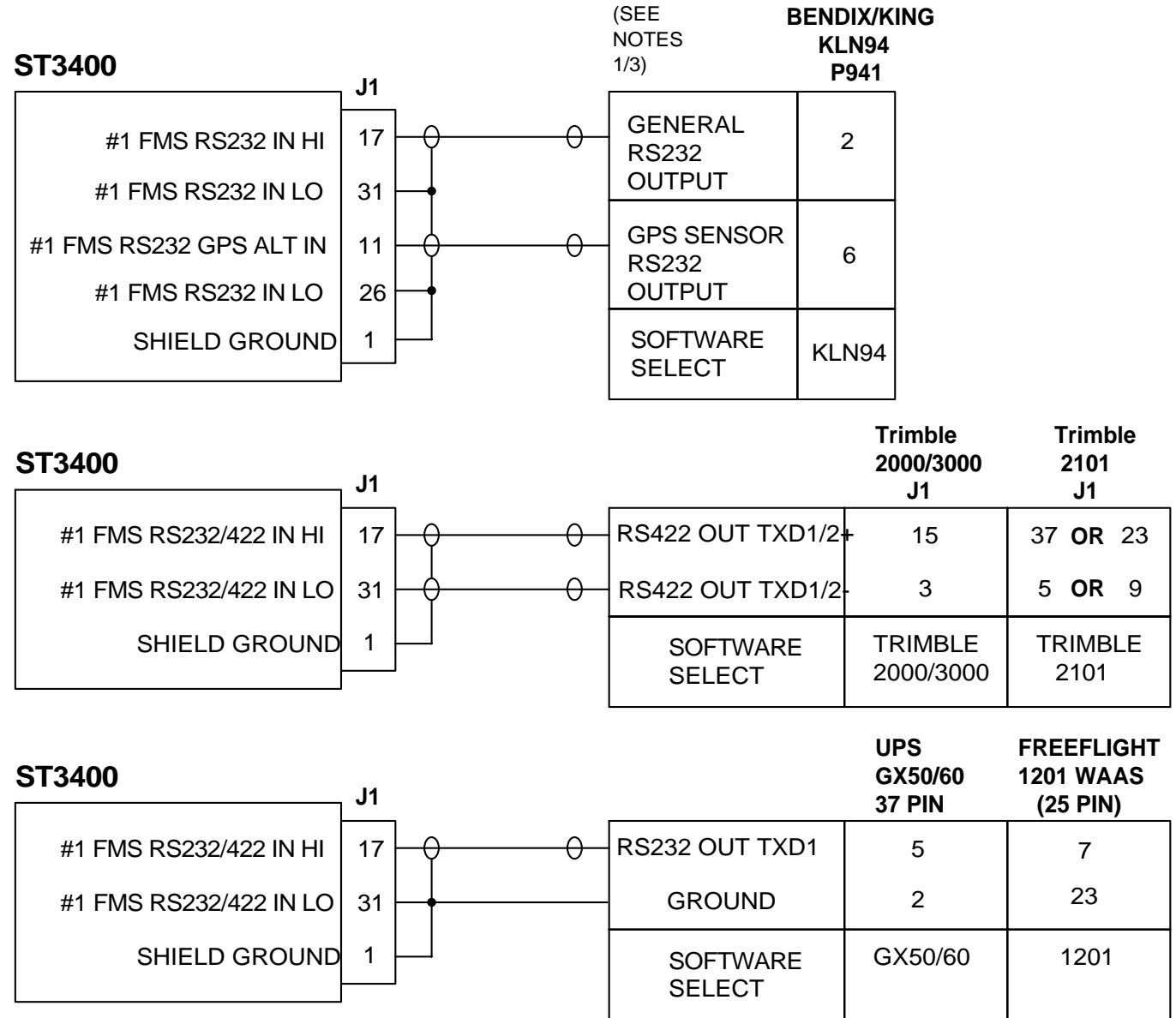

### GPS/FMS 2

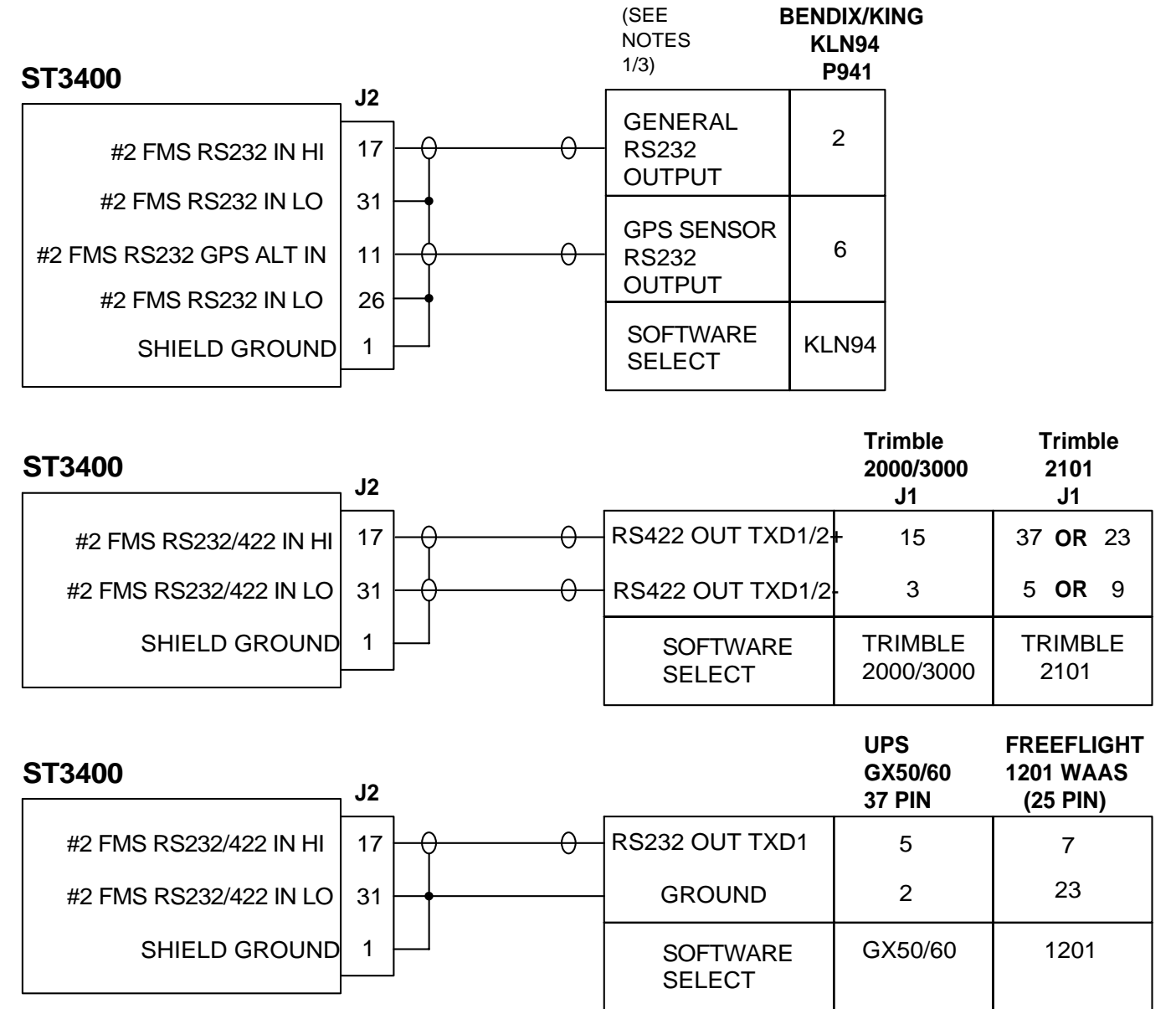

#### NOTES:

- Horizontal Guidance only used.
- If GPS uses two RS232 ports, contact Sandel before interfacing an RS232 OAT source. See OAT page.
- KLN94 must have Software 0106 or above installed.
- 1201 GPS provides horizontal and vertical position. No flight plan data available.

<b>SANDEL</b>		Vista, Ca.
Category	ST3400 INSTALLATION DRAWING	
Title	RS232 GPS INTERFACE	
Size B	Document Number	Rev
	<b>82002-10</b>	<b>H</b>
Create: Monday, July 02, 2001		Mod: Wednesday, April 07, 2004 Sheet 5

DATE	REV	COMMENTS
02/21/03	E	A/R 610 INITIAL RELEASE
10/17/03	G1	A/R 661 Added 430/530 Connectors Designators

COMPUTER CONTROLLED DRAWING  
DO NOT REVISE MANUALLY

### GPS/FMS 1

#### ST3400

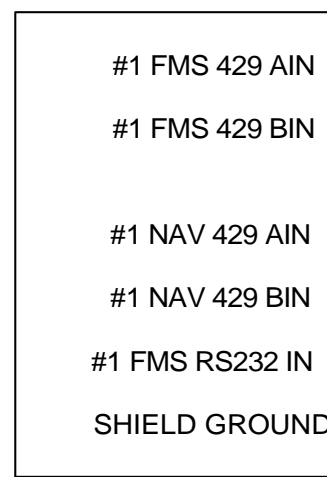

J1 PRIMARY

		GARMIN GNS-400/420 P4001	GARMIN GNS-500 P5001	GARMIN GNS-430 P4001	GARMIN GNS-530 P5001
ARINC 429 TX A	46	46	46	46	46
ARINC 429 TX B	47	47	47	47	47
NAV 429 A TX			P4006 24	P5006 24	
NAV 429 B TX			23	23	
RS232 TX	Select 1 of the 4 RS232 TX Outputs A Channel needs to be dedicated to the ST3400				

### GPS/FMS 2

#### ST3400

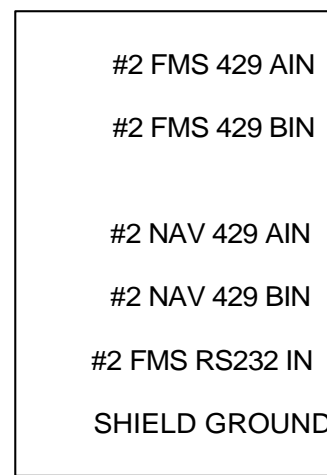

J2 SECONDARY

		GARMIN GNS-400/420 P4001	GARMIN GNS-500 P5001	GARMIN GNS-430 P4001	GARMIN GNS-530 P5001
ARINC 429 TX A	46	46	46	46	46
ARINC 429 TX B	47	47	47	47	47
NAV 429 A TX			P4006 24	P5006 24	
NAV 429 B TX			23	23	
RS232 TX	Select 1 of the 4 RS232 TX Outputs A Channel needs to be dedicated to the ST3400				

SECONDARY INPUTS OPTIONAL

### NOTES:

- GARMIN 400/500 SERIES UNITS MUST HAVE MAIN & GPS SOFTWARE 3.0 OR ABOVE. GARMIN 400/500 SERIES UNITS MUST HAVE PRESSURE ALTITUDE INTERFACED TO RECEIVER
- ST3400 MAINTENANCE PAGE ITEMS:  
 LNAV-1: GNS4XX/5XX (429\_232)  
 LNAV-2: GNS4XX/5XX (429\_232)  
 NAV-1: 429 (430/530)  
 NAV-2: 429 (430/530)  
 GS-1: 429 (430/530)  
 GS-2: 429 (430/530)
- GARMIN SETUP ITEMS  
 MAIN ARINC-429 CONFIGURATION RECEIVER 1:  
 OUT: LOW, GAMA 429 Graphics w/Int  
 SDI: LNAV 1 (SDI1)  
 VOR/LOC/GS ARINC-429 CONFIGURATION:  
 SPD RX: LOW  
 SPD TX: LOW  
 SDI: VOR/ILS 1 (SDI1)  
 MAIN RS232 CONFIG  
 INPUT OUTPUT  
 CHAN 1-4 OFF HW-EPGWS  
 MAIN ARINC-429 CONFIGURATION RECEIVER 2:  
 OUT: LOW, GAMA 429 Graphics w/Int  
 SDI: LNAV 2 (SDI2)  
 VOR/LOC/GS ARINC-429 CONFIGURATION:  
 SPD RX: LOW  
 SPD TX: LOW  
 SDI: VOR/ILS 2 (SDI2)  
 MAIN RS232 CONFIG  
 INPUT OUTPUT  
 CHAN 1-4 OFF HW-EPGWS

<b>SANDEL</b>		Vista, Ca.
Category	ST3400 INSTALLATION DRAWING	
Title	GARMIN GNS4XX/5XX	
Size B	Document Number <b>82002-10</b>	Rev <b>G1</b>
Create: Monday, July 02, 2001		Mod: Wednesday, April 07, 2004 Sheet 6

DATE	REV	COMMENTS
04/11/02	A	A/R 484 INITIAL RELEASE
09/25/02	B	A/R 564 added RA1 & RA2 FAIL
02/21/03	C	A/R 610 Depict J1 & J2 Separately ARINC 429 moved to page 8 Added Collins Ind 339H-4/4A, Sperry RT220 and RT300.
02/18/04	H	A/R 675 Corrected Errors in KRA 405 Interconnect Added Decision Height Discrete Input Removed #2 Rad Altimeter Input. Added new info on Sperry RT's and interconnects

COMPUTER CONTROLLED DRAWING  
DO NOT REVISE MANUALLY

### Radar Altimeter Analog

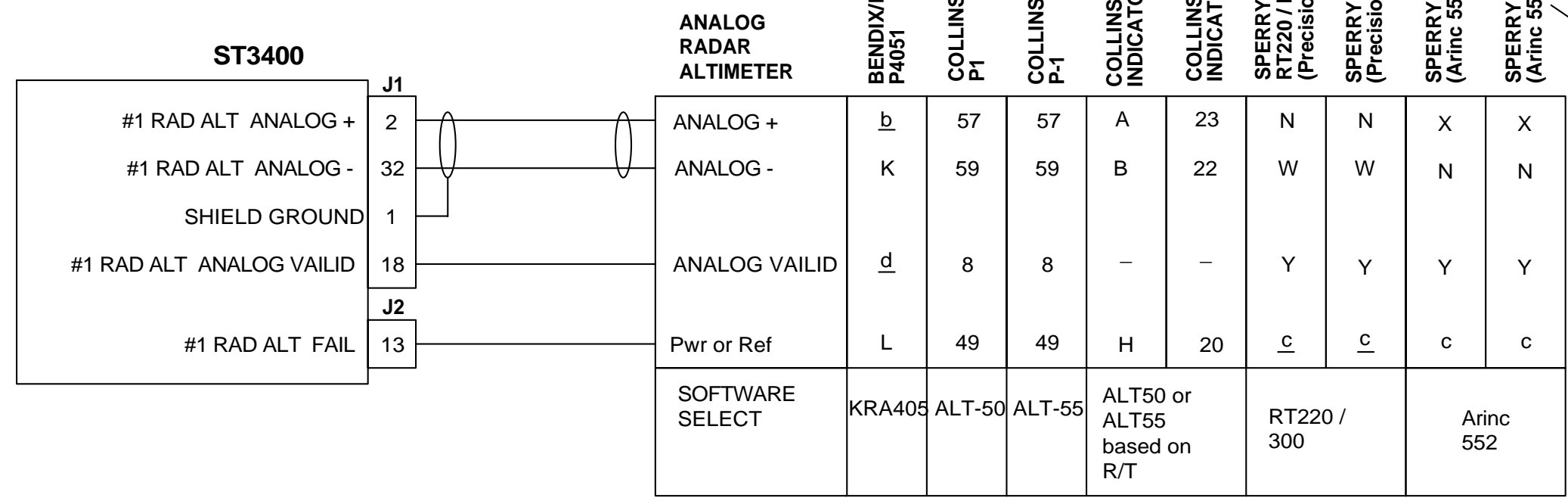

Dash numbers 9X2, 9X6, 9X7, 9X8 ONLY (0-2500')

**NOTE:** Use caution in specifying, configuring, and testing analog radar altimeters. Arinc 552 may produce the same readings as other configurations below 480' and different readings above 480'. Therefore, if configuration is mis-set a simple ground-test is not a complete test of all altitudes. If any question exists about the suitability of an installation, perform a flight test in VFR conditions and view the RA altitude readout on the ST3400 RA Maintenance page to verify the ST3400 data matches the pilot's radar altitude indicator through the entire usable range of 0-2000' or 0-2500'.

### DH (Minimums Callout)

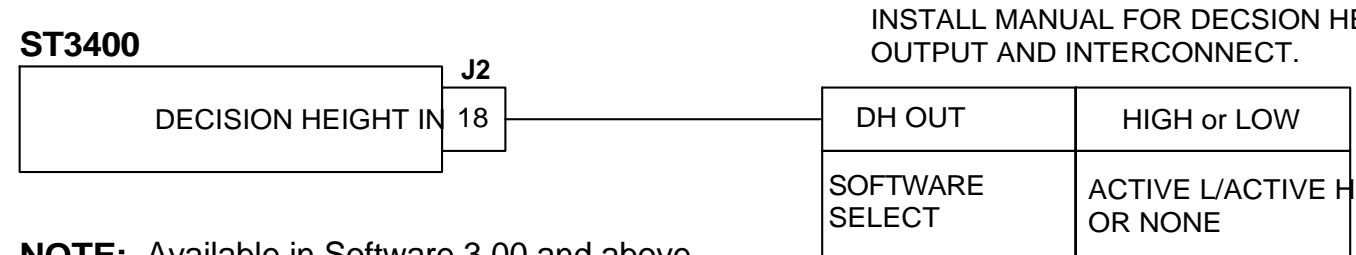

SEE RADAR ALTIMETERS MFG INSTALL MANUAL FOR DECSION HEIGHT OUTPUT AND INTERCONNECT.

**NOTE:** Available in Software 3.00 and above

- NOTES:**
1. SIGNALS MAY BE OBTAINED FROM R/T OR INDICATOR, AS REQUIRED.
  2. CONNECT ANALOG SIGNALS AS REQUIRED.

<b>SANDEL</b>		Vista, Ca.
Category	ST3400 INSTALLATION DRAWING	
Title	RADALT ANALOG	
Size B	Document Number	Rev
	<b>82002-10</b>	<b>H</b>
Create: Monday, July 02, 2001		Mod: Wednesday, April 07, 2004 Sheet 7

DATE	REV	COMMENTS
02/21/03	E	A/R 610 Radar Altimeter ARINC 429 interface moved from original sheet 5, added Bendix/King KRA405B
02/18/04	H	A/R 675 Removed #2 Radar Altimeter

COMPUTER CONTROLLED DRAWING  
DO NOT REVISE MANUALLY

### Radar Altimeter 429

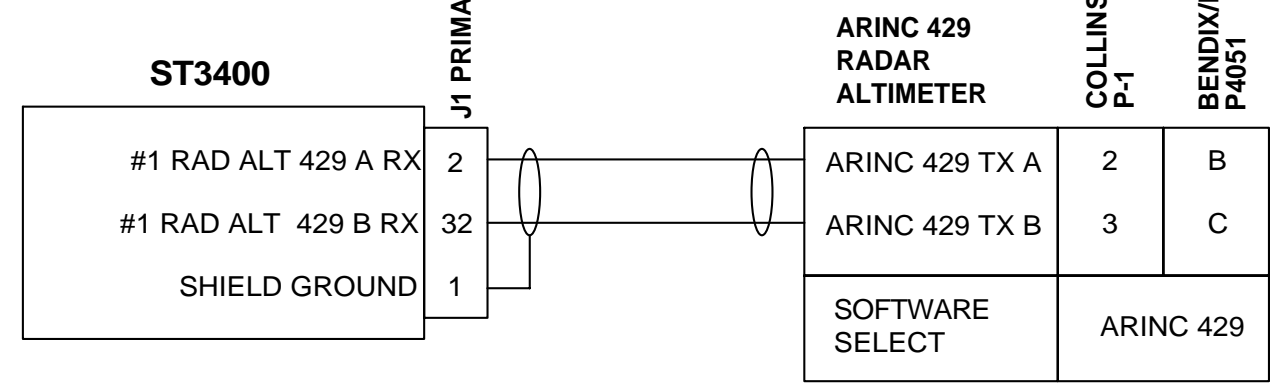

### DH (Minimums Callout)

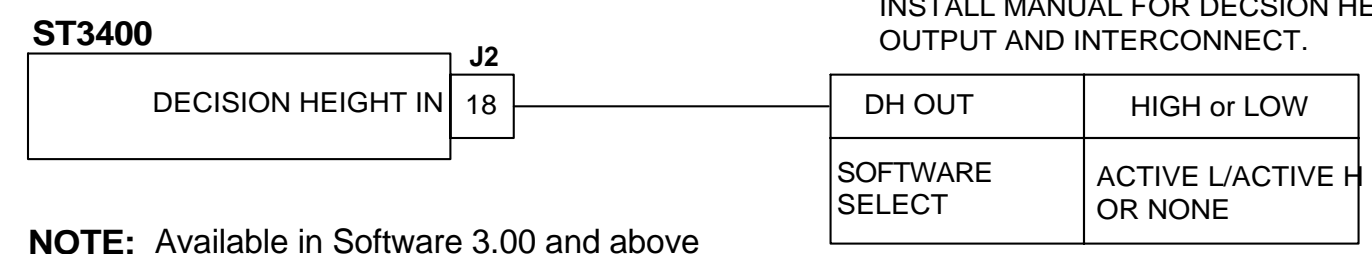

**NOTE:** Available in Software 3.00 and above

#### NOTES:

- SIGNALS MAY BE OBTAINED FROM R/T OR INDICATOR, AS REQUIRED.
- CONNECT DIGITAL SIGNALS AS REQUIRED.

<h1>SANDEL</h1>		Vista, Ca.
Category: ST3400 INSTALLATION DRAWING		
Title: RADALT ARINC 429		
Size: B	Document Number: <b>82002-10</b>	Rev: <b>H</b>
Create: Monday, July 02, 2001		Mod: Wednesday, April 07, 2004   Sheet 8

DATE	REV	COMMENTS
04/11/02	A	A/R 484 INITIAL RELEASE
02/21/03	B	A/R 610 Depict J1 & J2 Separately XYZ HDG moved to page 10
04/14/03	F	A/R 626 Added Note 1

COMPUTER CONTROLLED DRAWING  
DO NOT REVISE MANUALLY

### HDG 1 429

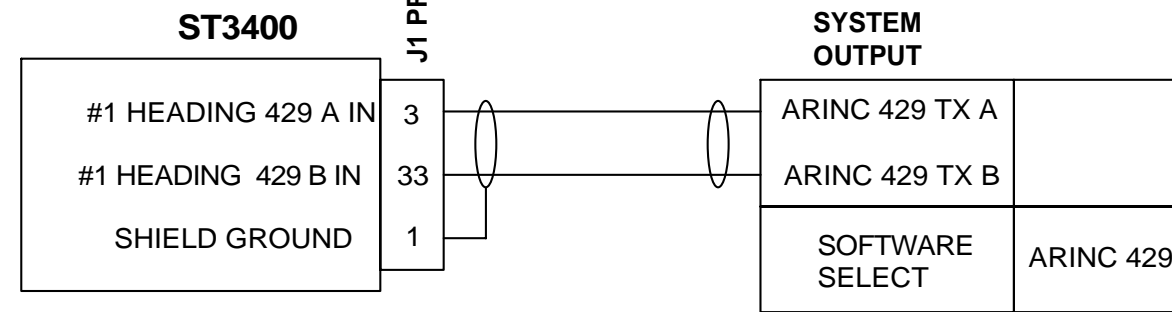

### HDG 2 429

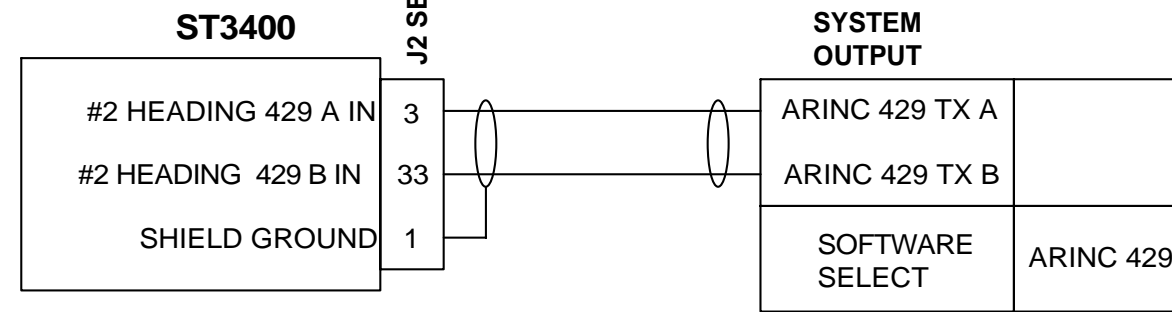

**SECONDARY INPUTS OPTIONAL**

**NOTES:**

- #2 Heading not available when XYZ used for Flaps. See Airframe page.

<b>SANDEL</b>		Vista, Ca.
Category	ST3400 INSTALLATION DRAWING	
Title	HDG ARINC 429	
Size B	Document Number	Rev
	<b>82002-10</b>	<b>F</b>
Create: Monday, July 02, 2001		Mod: Wednesday, April 07, 2004 Sheet 9

DATE	REV	COMMENTS
02/21/03	E	A/R 610 HDG XYZ interface moved from original sheet 6, added Bendix/King KCS55A, Collins MCS65 and Sperry C14A
04/14/03	F	A/R 626 Added Note 1
2/14/04	G	Removed note about flaps, now on P1

COMPUTER CONTROLLED DRAWING  
DO NOT REVISE MANUALLY

### HDG 1 XYZ

ST3400

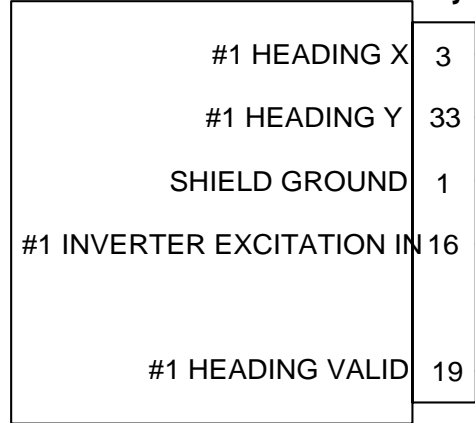

COMPASS SYSTEM OUTPUT	BENDIX/KING KCS 55A	BENDIX/KING KCS 305	COLLINS MCS 65	SPERRY
	KI525A P2	KSG 105 P1	DGS 65 P1	C-14A P1
HEADING X	<u>s</u>	Z OR L	25	L OR <u>a</u>
HEADING Y	<u>v</u>	W H	40	M <u>b</u>
HEADING Z	<u>t</u>	T D	24	K Z
EXCITATION HI	<u>r</u>	P <u>c</u>	6	H X
EXCITATION LO	<u>u</u>	<u>d</u> <u>f</u>	5	J Y
HEADING VALID	P	V V	50	<u>e</u> <u>e</u>
SOFTWARE SELECT	XYZ OR XYZ-180 HEADING VALID HI or LOW AS REQ'D			

**REQUIRES AC REFERENCE INPUT**

### HDG 2 XYZ

ST3400

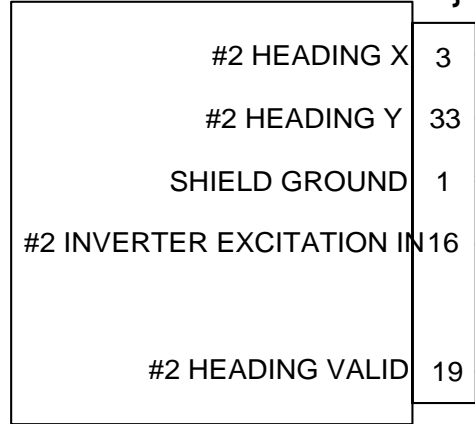

COMPASS SYSTEM OUTPUT	BENDIX/KING KCS 55A	BENDIX/KING KCS 305	COLLINS MCS 65	SPERRY
	KI525A P2	KSG 105 P1	DGS 65 P1	C-14A P1
HEADING X	<u>s</u>	Z OR L	25	L OR <u>a</u>
HEADING Y	<u>v</u>	W H	40	M <u>b</u>
HEADING Z	<u>t</u>	T D	24	K Z
EXCITATION HI	<u>r</u>	P <u>c</u>	6	H X
EXCITATION LO	<u>u</u>	<u>d</u> <u>f</u>	5	J Y
HEADING VALID	P	V V	50	<u>e</u> <u>e</u>
SOFTWARE SELECT	XYZ OR XYZ-180 HEADING VALID HI or LOW AS REQ'D			

**REQUIRES AC REFERENCE INPUT**

#2 Optional

<b>SANDEL</b>		Vista, Ca.
Category	ST3400 INSTALLATION DRAWING	
Title	HDG XYZ	
Size B	Document Number	Rev
	<b>82002-10</b>	<b>G</b>
Create: Monday, July 02, 2001		Mod: Wednesday, April 07, 2004 Sheet 10

DATE	REV	COMMENTS
04/11/02	A	A/R 484 INITIAL RELEASE
02/21/03	B	A/R 610 Depict J1 & J2 Separately XYZ ADF moved to page 12 SIN/COS ADF moved to page 13 Added Collins ADF-462

COMPUTER CONTROLLED DRAWING  
DO NOT REVISE MANUALLY

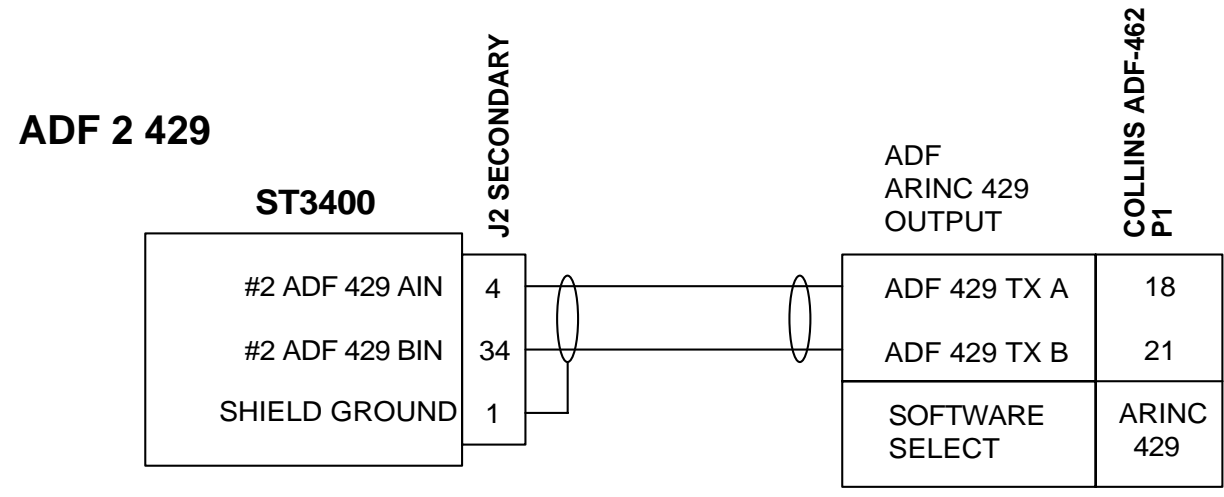
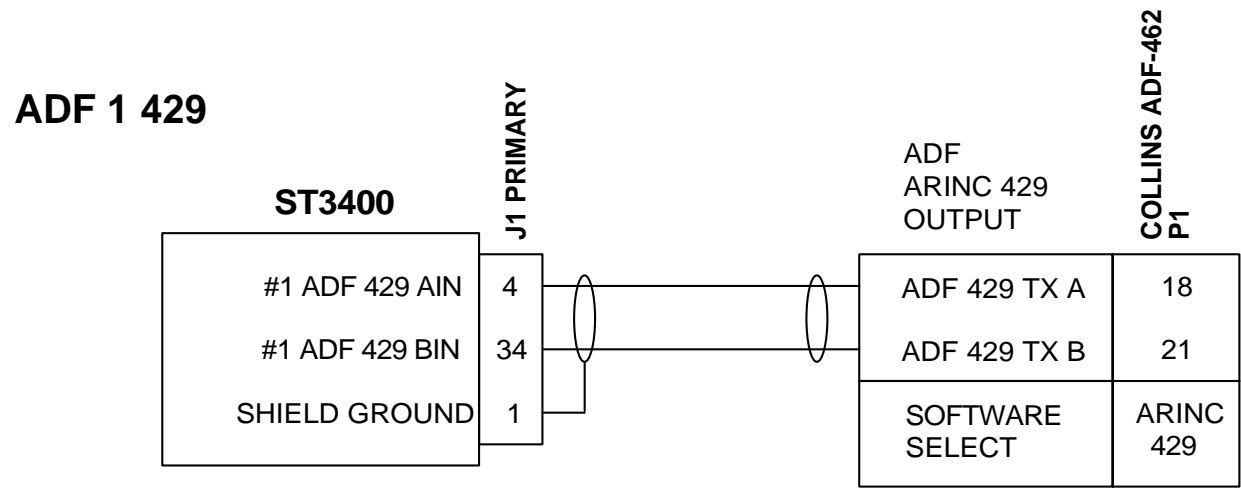

**SECONDARY INPUTS OPTIONAL**

- NOTES:**
- OPTIONAL - USED FOR RMI OPERATION ONLY.

<b>SANDEL</b>		Vista, Ca.
Category	ST3400 INSTALLATION DRAWING	
Title	ADF ARINC 429	
Size B	Document Number	Rev
	<b>82002-10</b>	<b>B</b>
Create: Monday, July 02, 2001		Mod: Wednesday, April 07, 2004 Sheet 11

DATE	REV	COMMENTS
02/21/03	E	A/R 610 Depict J1 & J2 Separately, Added Collins ADF-60A
10/17/03	G1	A/R 661 ADF Valid input Optional

COMPUTER CONTROLLED DRAWING  
DO NOT REVISE MANUALLY

### ADF 1 XYZ

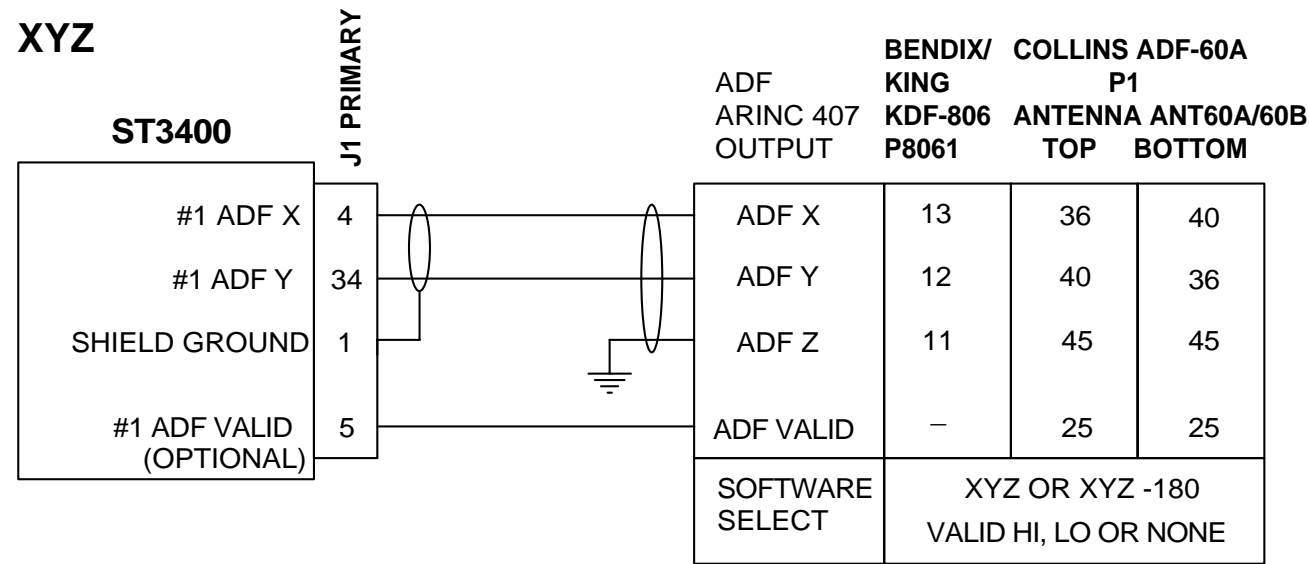

**REQUIRES AC REFERENCE INPUT**

### ADF 2 XYZ

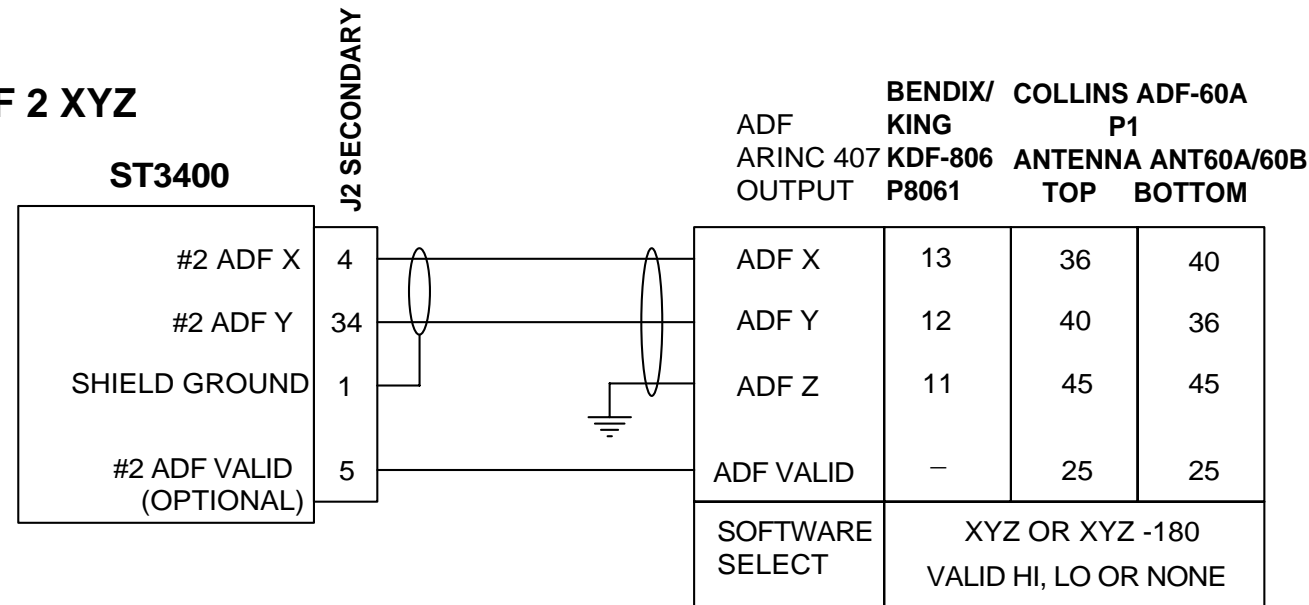

**REQUIRES AC REFERENCE INPUT**

**SECONDARY INPUTS OPTIONAL**

**NOTES:**

- OPTIONAL - USED FOR RMI OPERATION ONLY.

<b>SANDEL</b>		Vista, Ca.
Category	ST3400 INSTALLATION DRAWING	
Title	ADF XYZ	
Size B	Document Number	Rev
	<b>82002-10</b>	<b>G1</b>
Create: Monday, July 02, 2001		Mod: Wednesday, April 07, 2004 Sheet 12

DATE	REV	COMMENTS
02/21/03	E	AR610 Depict J1 & J2 Separately, Added Bendix/King KR-87 and Collins ADF-60A/B
10/17/03	G1	A/R 661 ADF Valid input Optional

COMPUTER CONTROLLED DRAWING  
DO NOT REVISE MANUALLY

### ADF 1 SIN/COS

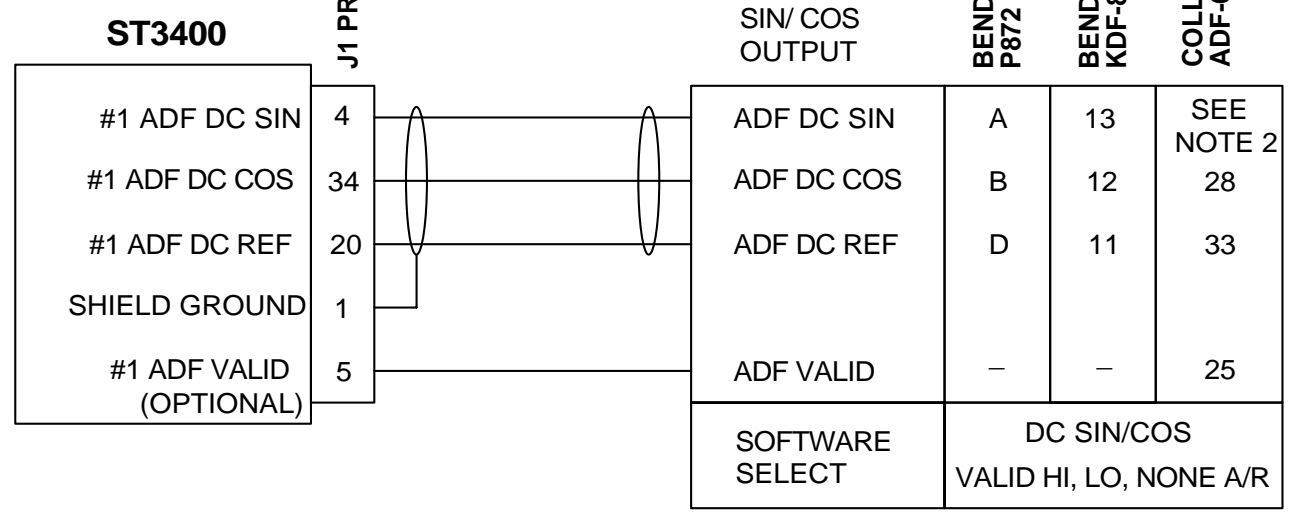

### ADF 2 SIN/COS

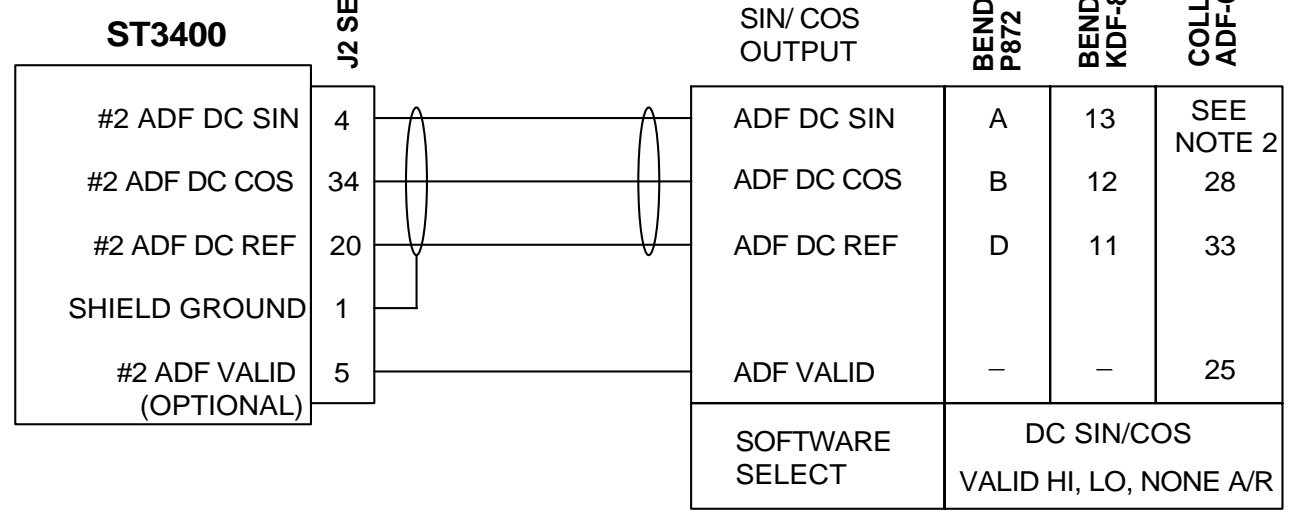

SECONDARY INPUTS OPTIONAL

- NOTES:**
- OPTIONAL - USED FOR RMI OPERATION ONLY.
  - TOP MOUNTED ANT 60A/B CONNECT PIN 24  
BOTTOM MOUNTED ANT 60A/B CONNECT PIN 32

<b>SANDEL</b>		Vista, Ca.
Category	ST3400 INSTALLATION DRAWING	
Title	ADF DC SIN/COS	
Size B	Document Number	Rev
	<b>82002-10</b>	<b>G1</b>
Create: Monday, July 02, 2001		Mod: Wednesday, April 07, 2004 Sheet 13

DATE	REV	COMMENTS
04/11/02	A	A/R 484 INITIAL RELEASE
05/21/02	B	A/R 525 Revised Glideslope Deviation
09/25/02	C	A/R 564 Corrected Nav 1 & 2 Composite Inputs
02/21/03	D	A/R 610 Depict J1 & J2 Separately ARINC 429 Nav moved to Page 15, added KX155/165 and Glideslope SuperFlag interface.
10/17/03	G1	A/R 661 Added 28VDC for Glideslope Superflag
02/18/04	H	A/R 675 Added Back Course Input

COMPUTER CONTROLLED DRAWING  
DO NOT REVISE MANUALLY

### NAV1/GS1 ANALOG

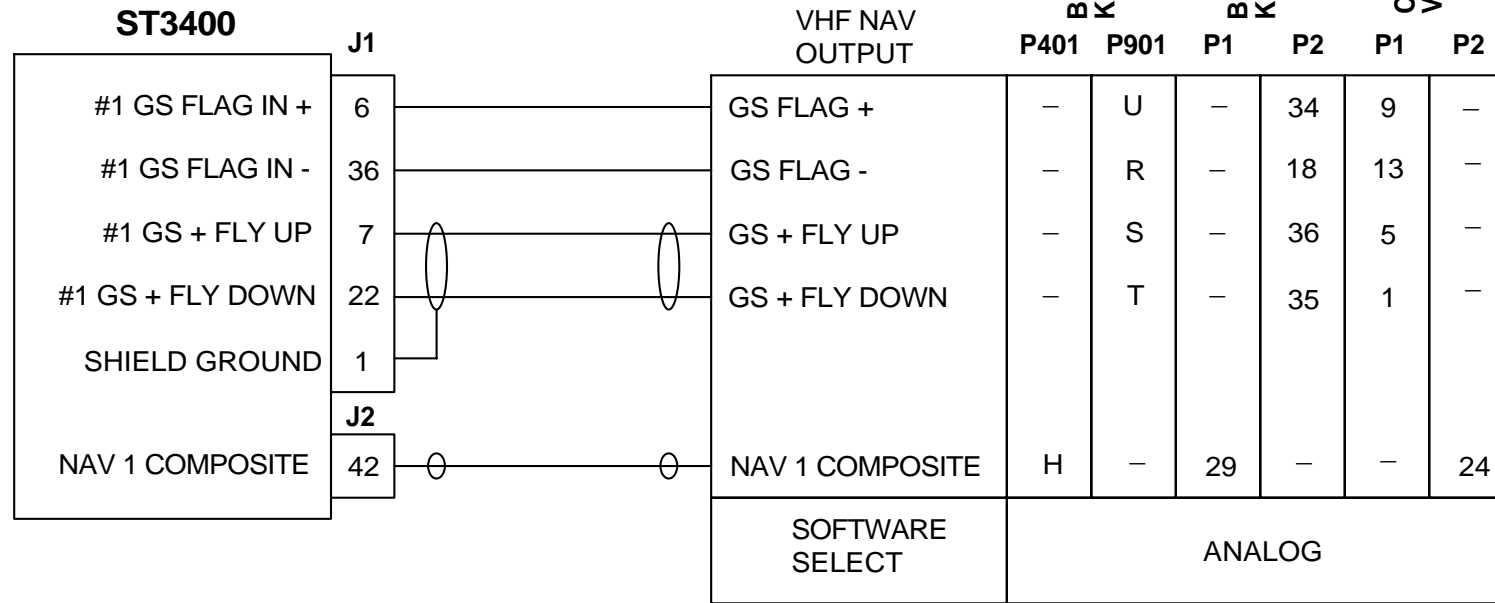

### Superflag (Alternate)

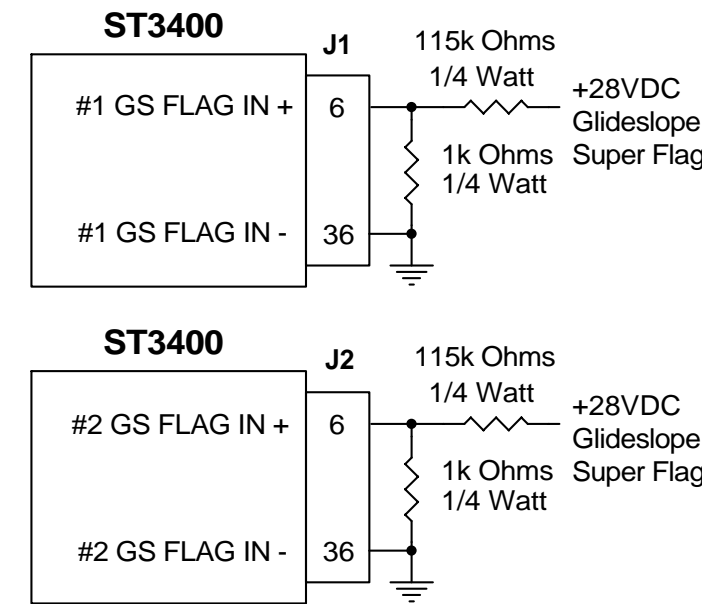

### SECONDARY INPUTS OPTIONAL

### NAV2/GS2 ANALOG

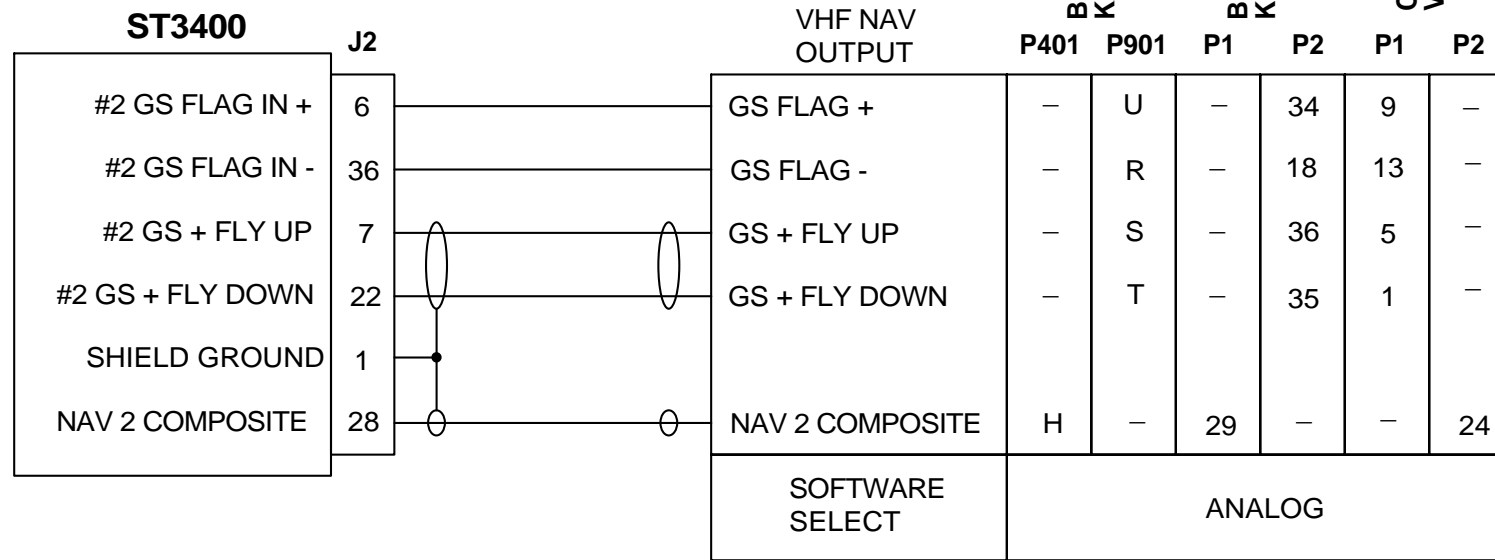

### SECONDARY INPUTS OPTIONAL

### Back Course (Mode 5 Inhibit)

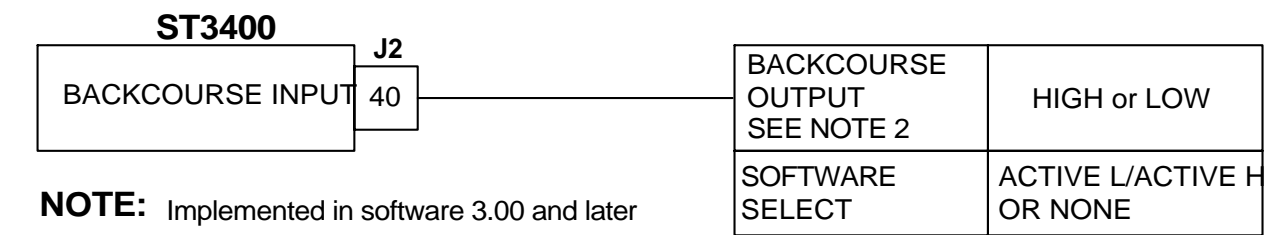

**NOTE:** Implemented in software 3.00 and later

- NOTE:**
- ILS ENERGIZE IS NOT REQUIRED.
  - MAY COME FROM HSI OR FCS ANNUNCIATOR

**SANDEL** Vista, Ca.

Category: ST3400 INSTALLATION DRAWING

Title: NAV & LOC ANALOG

Size B Document Number: **82002-10** Rev: **H**

Create: Monday, July 02, 2001 | Mod: Wednesday, April 07, 2004 | Sheet 14

DATE	REV	COMMENTS
02/21/03	E	AR 610 Nav ARINC 429 interface moved from original sheet 8. Added VIR 432, Garmin 430/530.

COMPUTER CONTROLLED DRAWING  
DO NOT REVISE MANUALLY

### NAV1/GS1 429

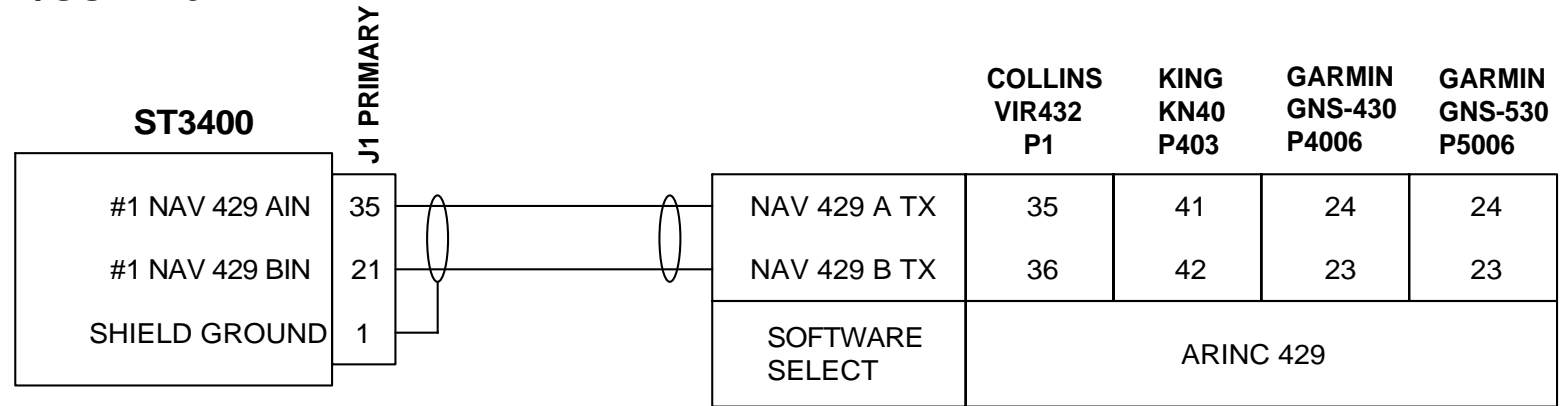

### NAV2/GS2 429

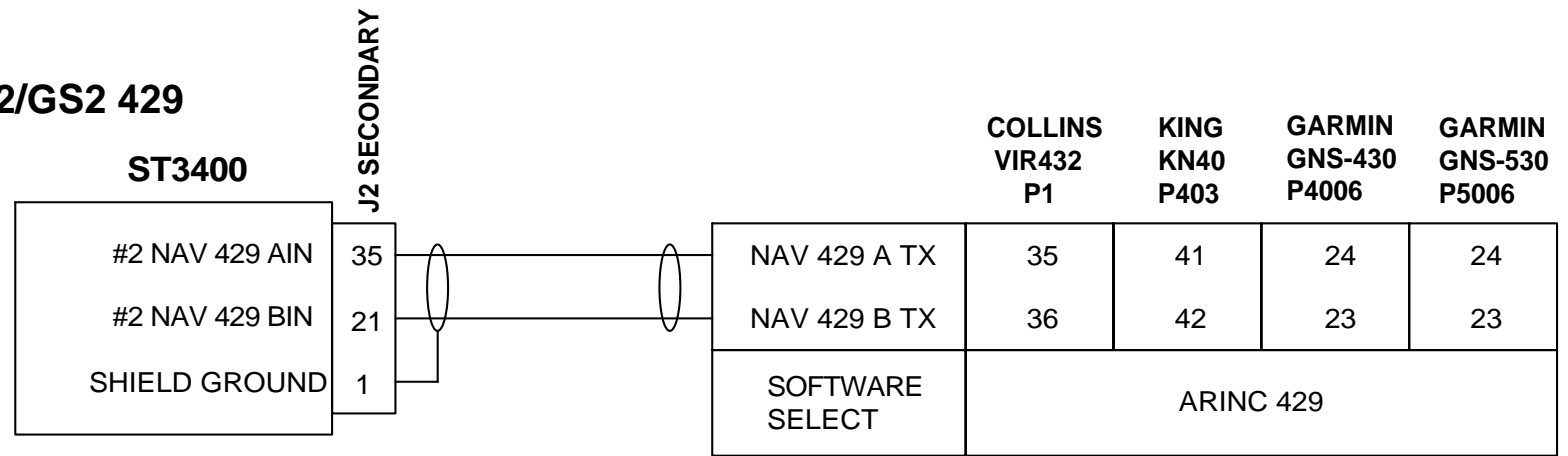

**SECONDARY INPUTS OPTIONAL**

<b>SANDEL</b>		Vista, Ca.
Category	ST3400 INSTALLATION DRAWING	
Title	NAV & LOC ARINC 429	
Size B	Document Number <b>82002-10</b>	Rev <b>E</b>
Create: Monday, July 02, 2001		Mod: Wednesday, April 07, 2004   Sheet 15

DATE	REV	COMMENTS
04/11/02	A	A/R 484 INITIAL RELEASE
06/21/02	B	A/R 547 ADDED OAT
02/21/03	C	A/R 610 Depict J1 & J2 Separately
04/14/03	F	A/R 626 Moved OAT to Page 18
02/18/04	H	A/R 675 Corrected pinout callouts on AZ-241. Removed #2 Analog Airdata & added Penny & Giles D60286
03/17/04	H1	A/R 690 Added note on Pressure Altitude and interface for the AZ-600.
07/01/04	J	A/R 717 Added interfaces for the Honeywell AZ-648 & CIC 04077 Mod 3.

COMPUTER CONTROLLED DRAWING  
DO NOT REVISE MANUALLY

### Airdata Analog For GPWS Only (No Altitude)

ST3400

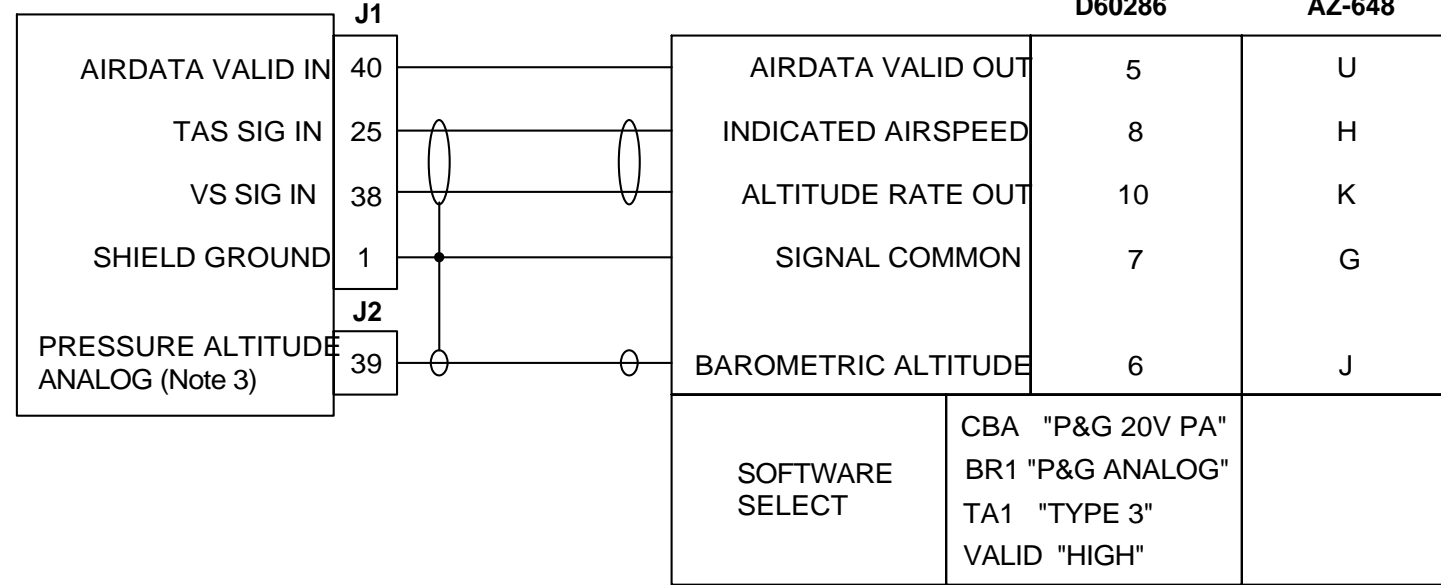

### Honeywell Analog With Altitude

ST3400

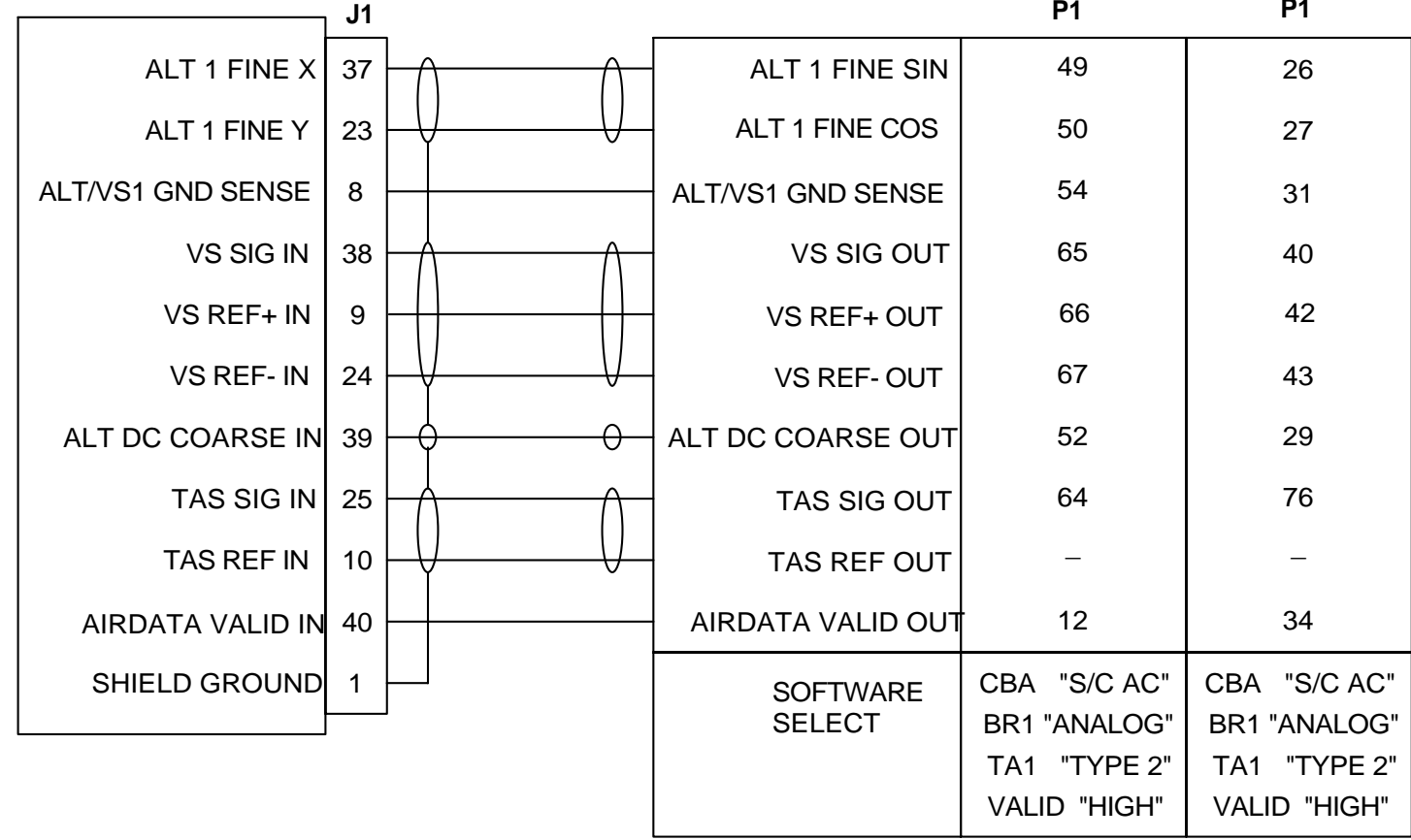

### CIC Airdata Analog For GPWS Only (No Altitude)

ST3400 (Mod A Only)

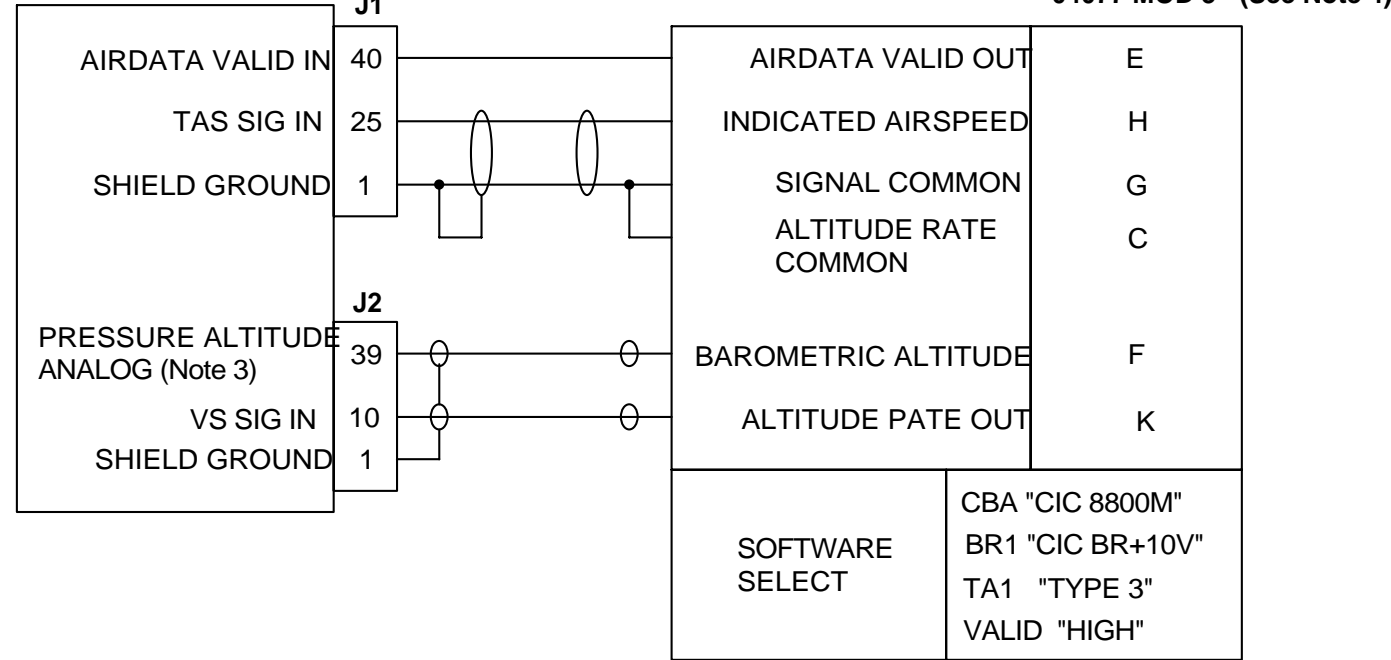

#### NOTES:

1. See Section 3, Interface Functions for OAT Probe Requirements
2. See Manufacturer's Manual for Complete Interconnect
3. Pressure Altitude Tolerance: Altitude +/- 500'; for 1000' change in altitude tolerance +/- 100'
4. Requires ST3400 Mod A

<b>SANDEL</b>		Vista, Ca.
Category	ST3400 INSTALLATION DRAWING	
Title	AIRDATA ANALOG	
Size B	Document Number	Rev
	<b>82002-10</b>	<b>J</b>
Create: Monday, July 02, 2001		Mod: Monday, August 09, 2004   Sheet 16

**SINGLE SOURCE ARINC 429 ST3400**

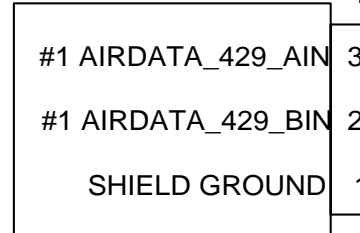

(See Note 1) (See Note 2)

	ADC-80 F/H/N J3	ADC-80 G/J/K/L/M/Q/R J3	ADC82( ) J3	ADC85 J2	AM250 J1	AZ252 J1A	AZ-810 J1B	IS&S ADDU P1	PENNY &GILES 90004-( ) 37 PIN	SHADIN ADC2000 P2
ARINC 429 TX A	31	36	36	1	Ports 1 - 3 1 Required	Ports 1 - 4 1 Required	Ports 1 - 2 1 Required	Ports 1 - 2 1 Required	27	7
ARINC 429 TX B	32	35	35	2					9	8
AIRDATA SELECT	MANCHSTR BUSS	ARINC 419	ARINC 419	ARINC 429	ARINC 429	ARINC 429	ARINC 429	ARINC 429	ARINC 429	ARINC 429
BARO RATE SELECT	B	B			B					A

**SPLIT SOURCE ARINC 429 ST3400**



ARINC 429 TX A	BARO CORRECTED ALTITUDE SOURCE
ARINC 429 TX B	
ARINC 429 TX A	TRUE AIRSPEED VERTICAL SPEED SOURCE
ARINC 429 TX B	
SOFTWARE SELECT	ARINC 429

**#2 DIGITAL SOURCE ARINC 429 ST3400**

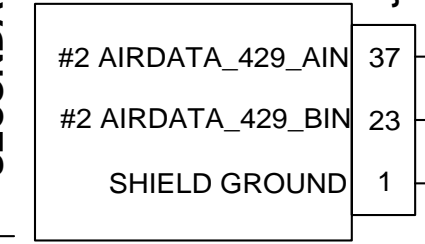

(See Note 1) (See Note 2)

	ADC-80 F/H/N J3	ADC-80 G/J/K/L/M/Q/R J3	ADC82( ) J3	ADC85 J2	AM250 J1	AZ252 J1A	AZ-810 J1B	IS&S ADDU P1	PENNY &GILES 90004-( ) 37 PIN	SHADIN ADC2000 P2
ARINC 429 TX A	31	36	36	1	Ports 1 - 3 1 Required	Ports 1 - 4 1 Required	Ports 1 - 2 1 Required	Ports 1 - 2 1 Required	27	7
ARINC 429 TX B	32	35	35	2					9	8
AIRDATA SELECT	MANCHSTR BUSS	ARINC 419	ARINC 419	ARINC 429	ARINC 429	ARINC 429	ARINC 429	ARINC 429	ARINC 429	ARINC 429
BARO RATE SELECT	B	B			B					A

SECONDARY INPUTS OPTIONAL

DATE	REV	COMMENTS
04/11/02	A	A/R 484 INITIAL RELEASE
05/21/02	B	A/R 525 Revised Single and Dual Airdata Interconnect
09/25/02	C	A/R 564 Added Penny & Giles Air Data Computer
10/24/02	D	A/R 578 Added Collins Air Data Computer Updated Title Block
02/21/03	E	A/R 610 Added Sperry AZ-252
04/14/03	F	A/R 626 Added ADC82, AM-250 & AZ-810.
08/04/03	G	A/R 638 Added IS&S.
10/17/03	G1	A/R 661 Added Collins ADC85 & Manchester Buss
02/18/04	H	A/R 675 Revised Note 1 on Collins Manchester Buss
09/01/04	J1	A/R 740 Corrected Type A and Type B Matrix

COMPUTER CONTROLLED DRAWING  
DO NOT REVISE MANUALLY

**NOTE:**

1. Collins Manchester OAT requires software 3.00 or above.
2. AM-250 Does not currently output OAT. Additional OAT input maybe required
3. Certain selections are circled to highlight differences.

**SANDEL**® Vista, Ca.

Category: ST3400 INSTALLATION DRAWING

Title: AIRDATA ARINC 429/419

Size B Document Number: **82002-10** Rev: **J1**

Create: Friday, March 22, 2002 Mod: Wednesday, September 01, 2004

DATE	REV	COMMENTS
04/14/03	F	A/R 626 INITIAL RELEASE

COMPUTER CONTROLLED DRAWING  
DO NOT REVISE MANUALLY

### OAT PROBE

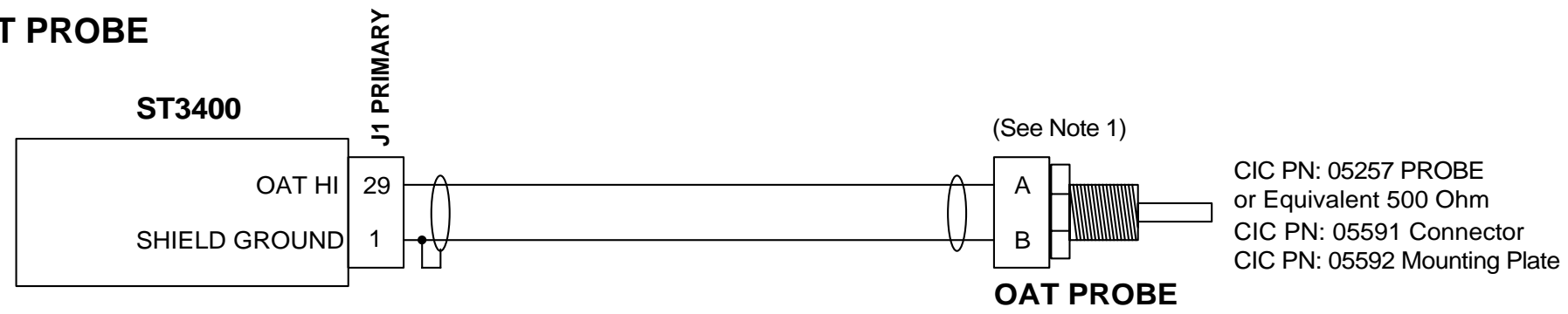

### OAT RS232

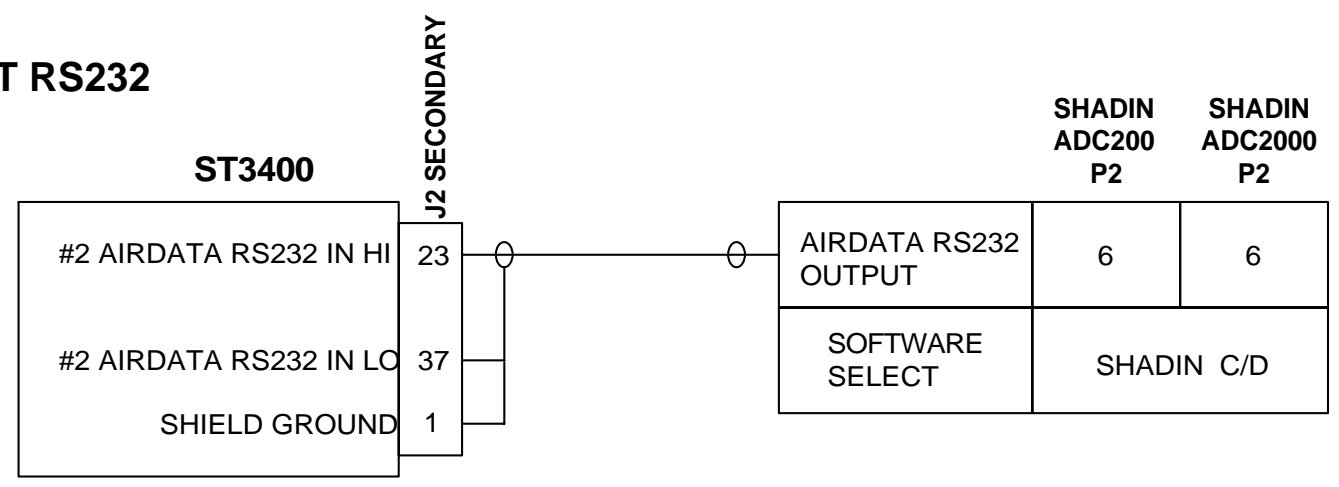

### OAT 429

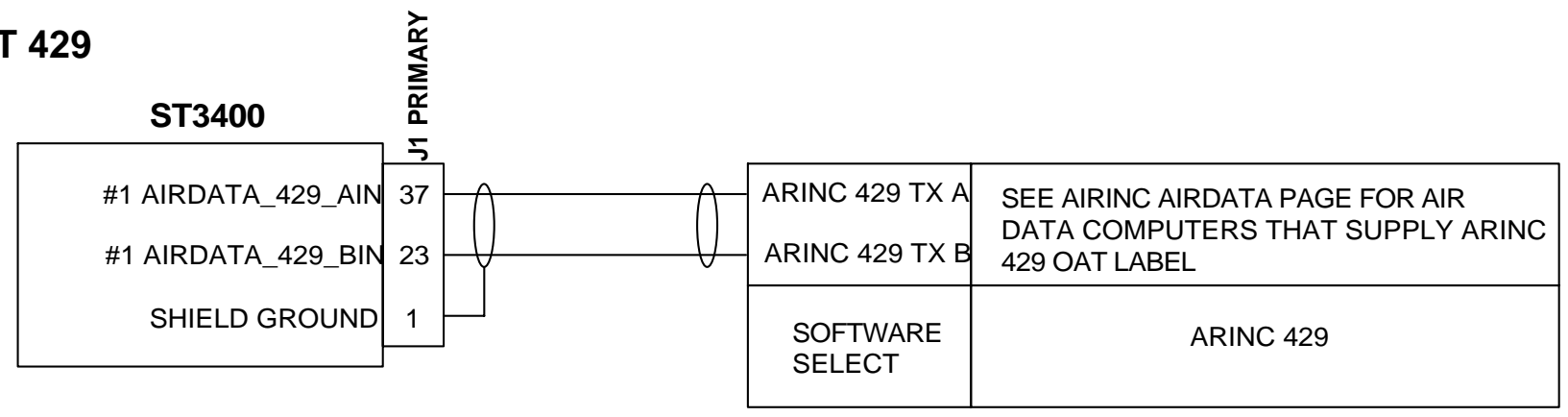

**NOTE:**

1. See Section 3 for OAT probe requirements.
2. If GPS receiver uses two RS232 ports, contact Sandel before interfacing OAT using RS232

<b>SANDEL</b>		Vista, Ca.
Category	ST3400 INSTALLATION DRAWING	
Title	OAT	
Size B	Document Number	Rev
	<b>82002-10</b>	<b>F</b>
Create: Monday, July 02, 2001		Mod: Wednesday, April 07, 2004   Sheet 18

DATE	REV	COMMENTS
04/11/02	A	A/R 484 INITIAL RELEASE
04/14/03	F	A/R 626 Added XYZ Flap Input
10/17/03	G1	A/R 661 Added Windshield Wiper Input
02/18/04	H	A/R 675 Changed Flap X/Y Input. Note removed

COMPUTER CONTROLLED DRAWING  
DO NOT REVISE MANUALLY

### Gear/Flap Discrete - Valid Low ST3400

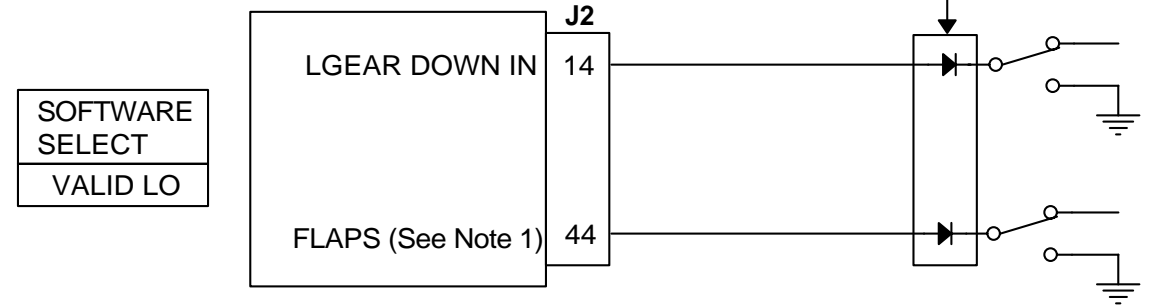

### Gear/Flap Discrete - Valid High ST3400

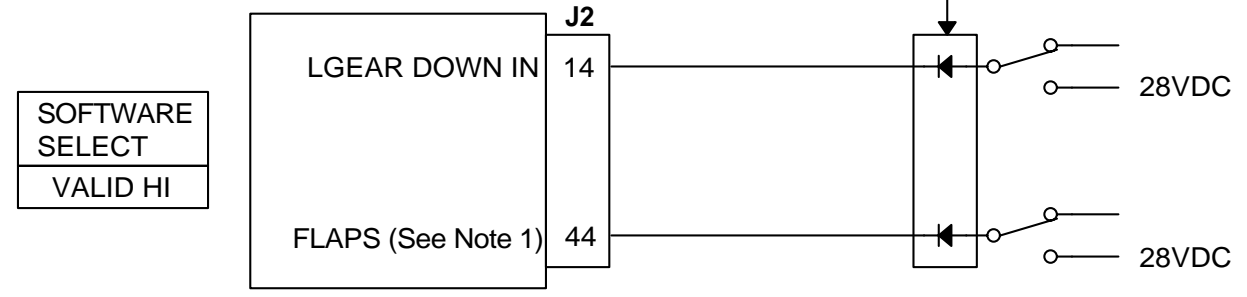

Note: For Gear/Flaps, any combination is permissible.

### AP Engage - Valid Low



### AP Engage - Valid High



### Flaps - XYZ

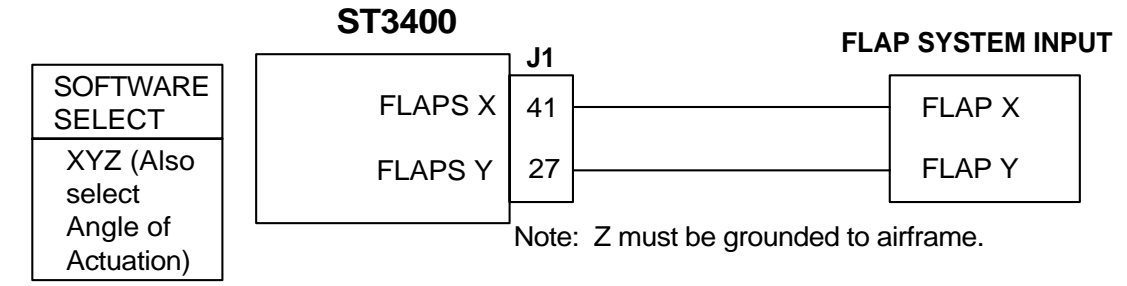

### WIPER - Valid Low

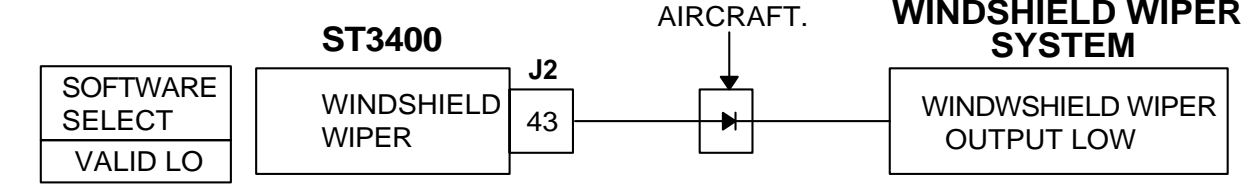

### WIPER - Valid High

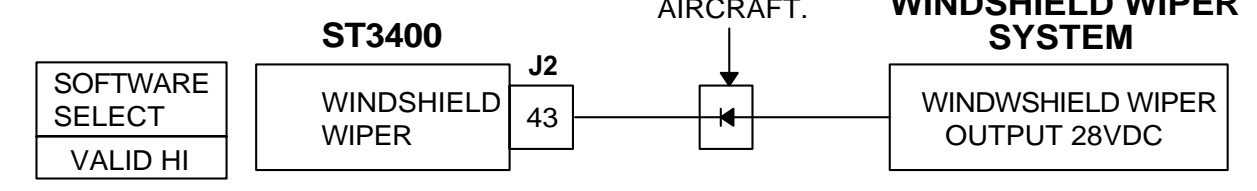

Note:

- The assertion of the flaps signal may be selected to indicate "flaps in landing configuration" or "flaps NOT in landing configuration". See Airframe maintenance page.

<b>SANDEL</b>		Vista, Ca.
Category	ST3400 INSTALLATION DRAWING	
Title	AIRFRAME	
Size B	Document Number	Rev
	<b>82002-10</b>	<b>H</b>
Create: Monday, July 02, 2001		Mod: Wednesday, April 07, 2004   Sheet 19

# ANNUNCIATORS AND EXTERNAL SWITCHES

ST3400

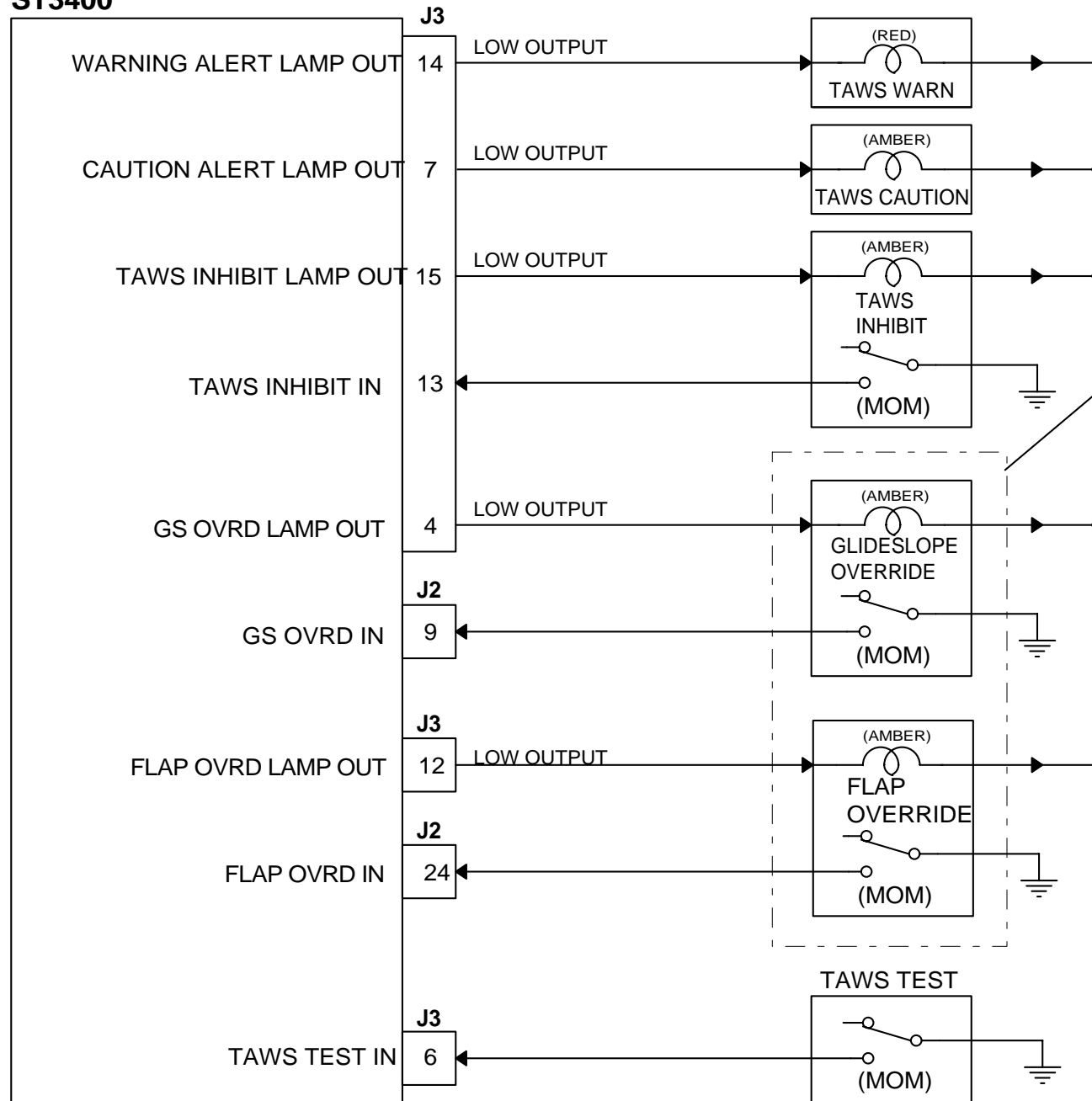

See Note 2

These Lamps/Switches operational in software 3.00 and later. Switch inputs also require MOD Level 2.

## CONFIGURABLE DISCRETE OUT

ST3400

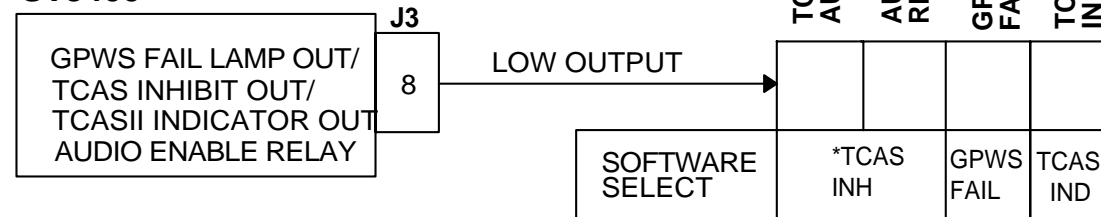

\*TCAS INH selection may be used to drive an 'TAWS audio enable' relay if desired. See page 3.

## FLIGHT DATA RECORDER

ST3400

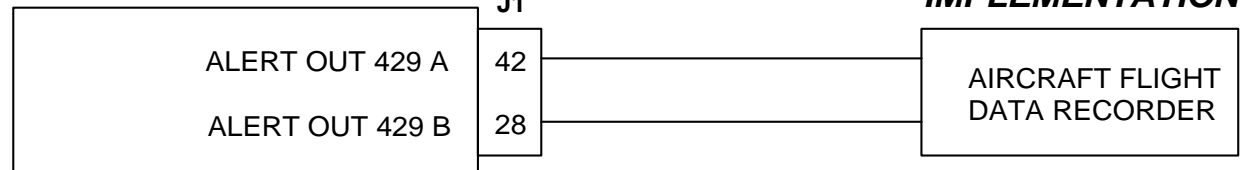

**FUTURE IMPLEMENTATION**

Diagram of each ST3400 Discrete Output (for reference)

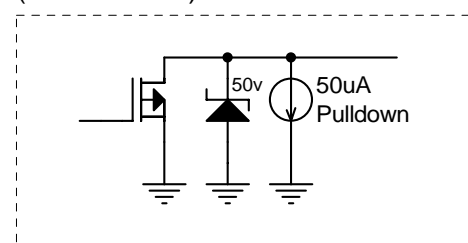

### NOTES:

- Annunciators and switches are optional.
- Annunciator power should be connected to Day/Light switch or photocell. Do not connect to panel lighting dimmer.

<b>SANDEL</b>		Vista, Ca.	
Category	ST3400 INSTALLATION DRAWING		
Title	ANNUNCIATORS (Optional)		
Size B	Document Number	<b>82002-10</b>	Rev <b>H2</b>
Create: Monday, July 02, 2001		Mod: Wednesday, April 14, 2004   Sheet 20	

DATE	REV	COMMENTS
04/11/02	A	A/R 484 INITIAL RELEASE
02/21/03	B	A/R 610 Depict J1 & J2 Separately Added TCAS/TRAFFIC Inhibit. Corrected mislabel on the Warning/Caution outputs.
08/04/03	G	A/R 638 Added separate TCAS/Traffic Inhibit Output Added "TAWS TEST" Input.
02/18/04	H	A/R 675 Changed "TAWS INHIBIT" to "ALERTS INHIBIT". Added GPWS Fail, Flap Ovrdr and Glideslope Ovrdr.
04/06/04	H2	A/R 697 Note on TCS INH. Added description of discrete output.

COMPUTER CONTROLLED DRAWING  
DO NOT REVISE MANUALLY

DATE	REV	COMMENTS
04/11/02	A	A/R 484 INITIAL RELEASE
02/24/04	A	Add note

COMPUTER CONTROLLED DRAWING  
DO NOT REVISE MANUALLY

## DUAL SYSTEM INTERLINK

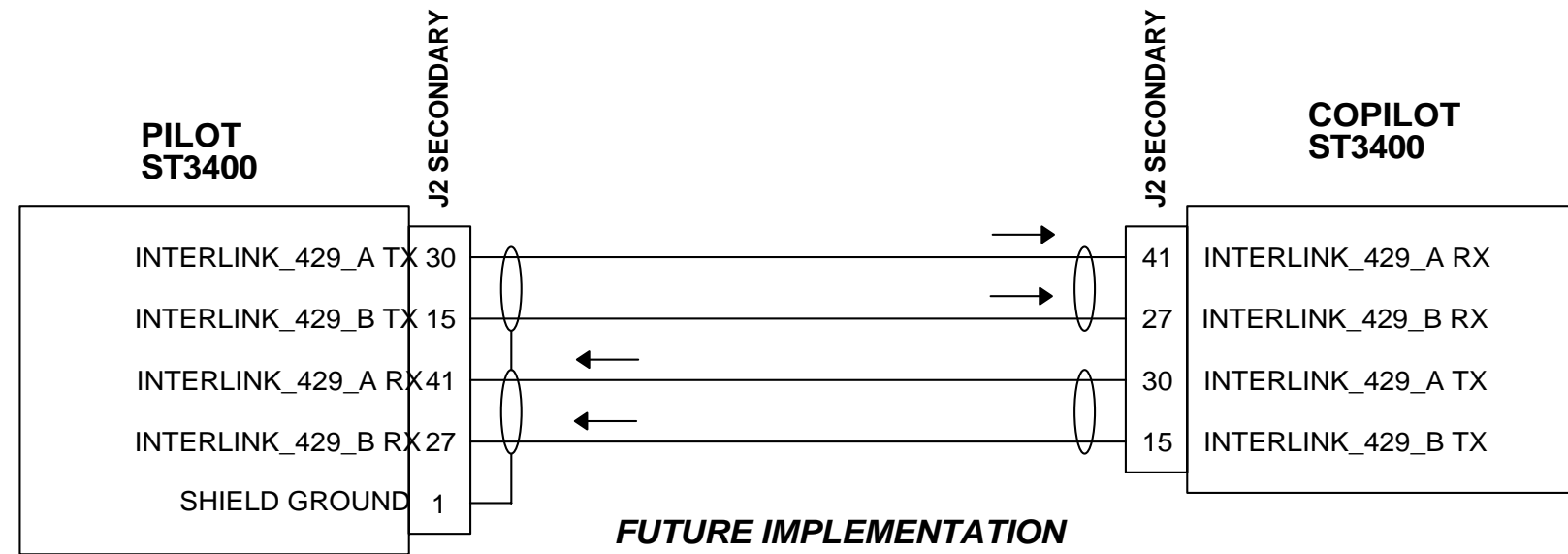

**FUTURE IMPLEMENTATION**  
*(Connection Recommended for Dual installs)*

<b>SANDEL</b>		Vista, Ca.
Category	ST3400 INSTALLATION DRAWING	
Title	INTERLINK	
Size B	Document Number <b>82002-10</b>	Rev <b>A1</b>
Create: Monday, July 02, 2001		Mod: Wednesday, April 07, 2004 Sheet 21

DATE	REV	COMMENTS
02/18/04	H	A/R 675 INITIAL RELEASE
04/06/04	H2	A/R 697 P3-8 Selection now "AUDIO ENA" instead of TCAS INH to allow operation during maintenance.
08/05/04	J	A/R 717 GOODRICH SKYWATCH P1 PIN 5 WAS 49

COMPUTER CONTROLLED DRAWING  
DO NOT REVISE MANUALLY

### TCAS 791

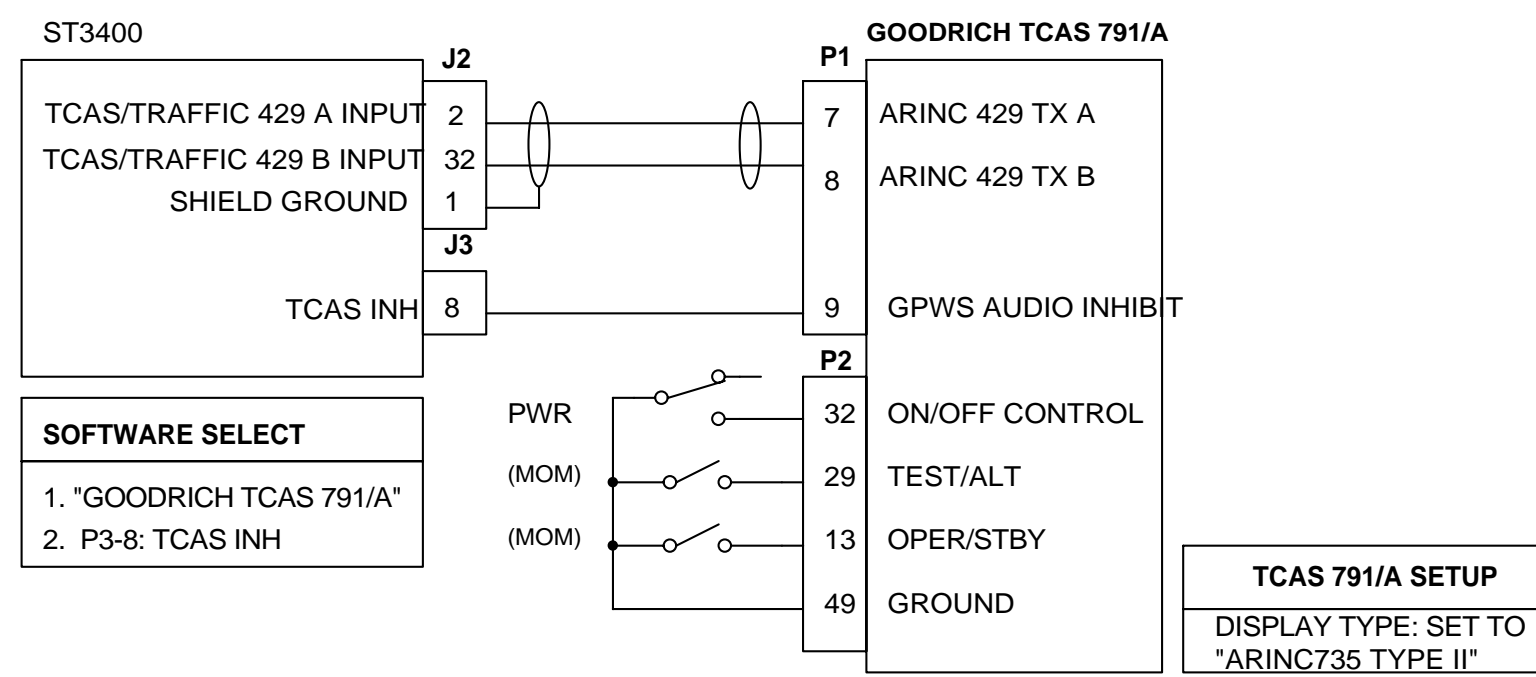

### SKYWATCH HP

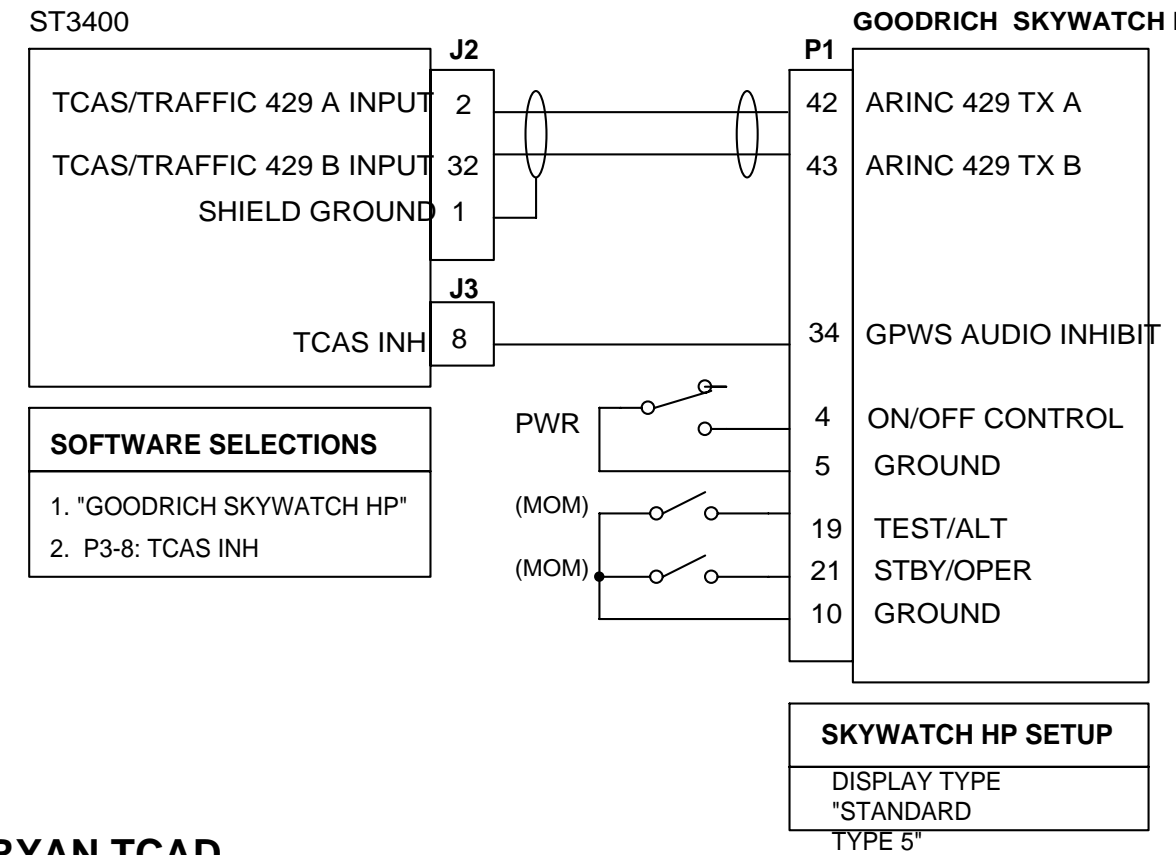

### CAS66

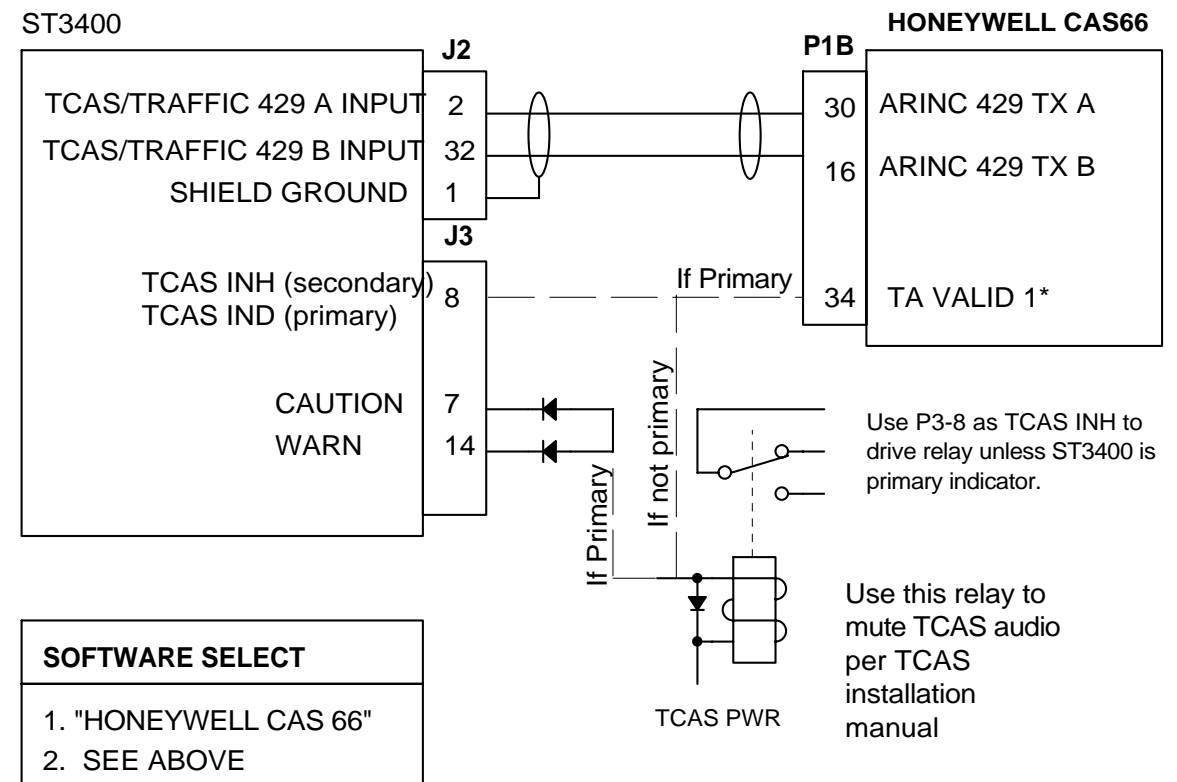

### RYAN TCAD

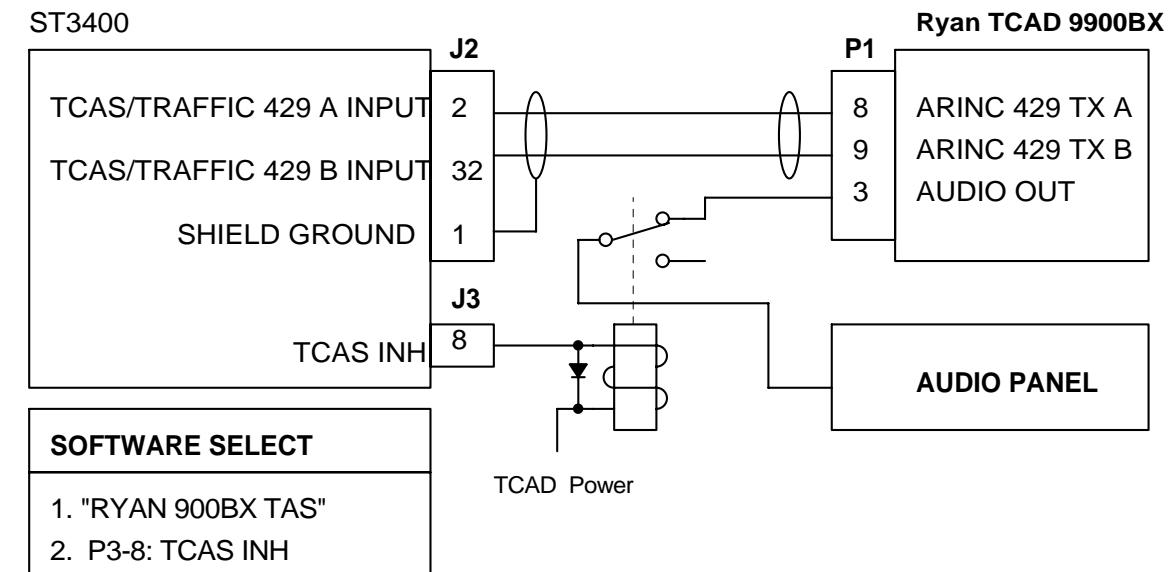

**NOTES:**

- Interconnect shown with Sandel ST3400 as primary Traffic display
- See Manufacturers Installation Manuals for complete wiring interface.
- ST3400 P3-8 Output is configured on Maintenance Page 2 (System).

**SANDEL** Vista, Ca.

Category: ST3400 INSTALLATION DRAWING

Title: TCAS / TRAFFIC

Size B Document Number **82002-10** Rev **J**

Create: Thursday, November 06, 2003 Mod: Monday, August 09, 2004 | Sheet 22